

**DEPARTMENT OF
MECHANICAL ENGINEERING**

LABORATORY MANUAL

**MECHANICAL ENGINEERING
(CSMSS/ENGG/MECH/ CAD LAB /MDCAD/ BTMCL305)**



CSMSS
CHH. SHAHU COLLEGE OF ENGINEERING
KANCHANWADI, CHHATRAPATI SAMBHAJINAGAR - 431011

	CHH. SHAHU COLLEGE OF ENGINEERING, AURANGABAD		LABORATORY MANUAL
	PRACTICAL EXPERIMENT INSTRUCTION SHEET		
	EXPERIMENT TITLE: Study of Redwood's Viscometer and determination of viscosity of lubricants		
DEPARTMENT:MECHANICAL ENGINEERING		LABORATORY :CSMSS/ENGG/MECH/CAD LAB	
LABORATORY MANUAL NO.:CSMSS/ENGG/MECH/CADLAB		YEAR:2024-25	
Class: Second Year	PART: I	SUBJECT: MDCAD	PAGE: 1 OF 5

VISION AND MISSION OF THE INSTITUTE

VISION

❖ To be an institution of repute through multidisciplinary educational approach to develop the next generation competent technocrats (engineering professionals) for industry and society.

❖ MISSION

M1	Developing student centric educational practices for curriculum delivery and assessment.
M2	imparting entrepreneurial and employability skills among students through value-based and skill-based training in collaboration with industry and academia.
M3	Inculcating social and professional values among students through awareness and outreach activities.
M4	Providing an environment for innovation and research through various interdisciplinary activities.

B. M. NETAKE
LAB INCHARGE

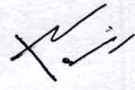
DR.R.H. SHINDE
HOD

	CHH. SHAHU COLLEGE OF ENGINEERING, AURANGABAD		LABORATORY MANUAL
	PRACTICAL EXPERIMENT INSTRUCTION SHEET		
EXPERIMENT TITLE: Study of Redwood's Viscometer and determination of viscosity of lubricants			
DEPARTMENT:MECHANICAL ENGINEERING		LABORATORY :CSMSS/ENGG/MECH/CAD LAB	
LABORATORY MANUAL NO.:CSMSS/ENGG/MECH/CADLAB		YEAR:2024-25	
Class: Second Year	PART: I	SUBJECT: MDCAD	PAGE: 2 OF 5

VISION AND MISSION OF THE DEPARTMENT

❖ VISION

To Be a Centre of Repute for Preparing Engineering Students as Professionals in the Services, Domain Leadership, Research, and Good Citizens.

❖ MISSION

M1: To develop the continuous improvement process in academic practices for strengthening the academic base of students.

M2: To develop the research culture through various efforts that can inspire students for research thought.

M3: Developing the students for social skills like team building, leadership and social values.

M4: Upgrading the above activities through communication with internal and external stake holders (Students, Parents, Alumni, Employers, Experts, Society people, etc.).

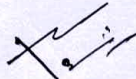

B. M. NETAKE
LAB INCHARGE

DR.R.H. SHINDE
HOD

	CHH. SHAHU COLLEGE OF ENGINEERING, AURANGABAD		LABORATORY MANUAL
	PRACTICAL EXPERIMENT INSTRUCTION SHEET		
	EXPERIMENT TITLE: Study of Redwood's Viscometer and determination of viscosity of lubricants		
DEPARTMENT:MECHANICAL ENGINEERING		LABORATORY :CSMSS/ENGG/MECH/CAD LAB	
LABORATORY MANUAL NO.:CSMSS/ENGG/MECH/CADLAB		YEAR:2024-25	
Class: Second Year	PART: I	SUBJECT: MDCAD	PAGE: 3 OF 5

COURSE OUTCOMES (COS)

COS	BT LEVEL
CO1: Students will be able to identify the object with the help of given sectional and orthographic view.	L1
CO2: Students will be able to Represent tolerances and level of surface finish on production drawings.	L2
CO3: Students Will be able to Draw machine element using keys, cotter, knuckle, bolted and welded joint.	L3
CO4: Students will be able to Classify various creating and editing commands in Auto Cad.	L4
CO5: Students Will be able to Construct the curve of intersection of two solids	L6
CO6: Students will be able to Assemble details of any given part. i. e. valve, pump, machine tool part etc.	L6

	CHH. SHAHU COLLEGE OF ENGINEERING, AURANGABAD		LABORATORY MANUAL
	PRACTICAL EXPERIMENT INSTRUCTION SHEET		
EXPERIMENT TITLE: Study of Redwood's Viscometer and determination of viscosity of lubricants			
DEPARTMENT:MECHANICAL ENGINEERING		LABORATORY :CSMSS/ENGG/MECH/CAD LAB	
LABORATORY MANUAL NO.:CSMSS/ENGG/MECH/CADLAB		YEAR:2024-25	
Class: Second Year	PART: I	SUBJECT: MDCAD	PAGE: 4 OF 5

MDCAD LAB (COURSE CODE-BTMCL305)

OBJECTIVE:

To develop skill to use software to create 2D and 3D models.

LIST OF EXPERIMENT:

1	"One full imperial drawing sheet consisting the drawing/sketches of representation of standard components, symbols of pipe joints, weld joints, rivet joint etc., surface finish symbols and grades, limit, fit and tolerance sketches"
2	"Two full imperial drawing sheets, one consisting of assembly and the other consisting of details of any one standard component such as valves, components of various machine tools, pumps, joints, engine parts, etc."
3	". Two assignments of AutoCAD: Orthographic Projections of any one simple machine component such as bracket, Bearing Housing or Cast component for Engineers such as connecting rod, Piston, etc.; with dimensioning and detailing of three views of components."
4	3-D model at least one simple machine component.



PRACTICAL EXPERIMENT INSTRUCTION SHEET

EXPERIMENT TITLE: One full imperial drawing sheet consisting the drawing/sketches of representation of standard components, symbols of pipe joints, weld joints, rivet joint etc.

DEPARTMENT: MECHANICAL ENGINEERING

LABORATORY: CSMSS/ENGG/MECH/MDCADLAB

LABORATORY MANUAL NO.: CSMSS/ENGG/MECH/MDCAD-01

YEAR:2024-25

Class: Second Year

PART: I

SUBJECT: Machine Drawing and CAD Lab

PAGE: 1 OF 4

Practical: 01

1. Draw One full imperial drawing sheet consisting the drawing/sketches of representation weld joints, rivet joint etc., surface finish symbols and grades, limit, fit and tolerance sketches.

EXERCISE-01

WELD SYMBOLS		
SQUARE BUTT WELD 	SINGLE V BUTT WELD 	SINGLE BEVEL BUTT WELD
SINGLE-U BUTT WELD 	SINGLE-J BUTT WELD 	BACKING RUN
FILLET WELD 	PLUG WELD 	SPOT WELD



PRACTICAL EXPERIMENT INSTRUCTION SHEET

EXPERIMENT TITLE: One full imperial drawing sheet consisting the drawing/sketches of representation of standard components, symbols of pipe joints, weld joints, rivet joint etc.

DEPARTMENT: MECHANICAL ENGINEERING

LABORATORY: CSMSS/ENGG/MECH/MDCADLAB

LABORATORY MANUAL NO.: CSMSS/ENGG/MECH/MDCAD-01

YEAR:2024-25

Class: Second Year

PART: I

SUBJECT: Machine Drawing and CAD Lab

PAGE: 2 OF 4

No.	Designation	Illustration	Symbol
1.	Butt weld between plates with raised edges (the raised edges being melted down completely)		
2.	Square butt weld		
3.	Single-V butt weld		
4.	Single-bevel butt weld		
5.	Single-V butt weld with broad root face		
6.	Single-bevel butt weld with broad root face		
7.	Single-U butt weld (parallel or sloping sides)		
8.	Single-U butt weld		
9.	Backing run; back or backing weld		
10.	Fillet weld		
11.	Plug weld; plug or slot weld		
12.	Spot weld		
13.	Seam weld		

Prepare



PRACTICAL EXPERIMENT INSTRUCTION SHEET

EXPERIMENT TITLE: One full imperial drawing sheet consisting the drawing/sketches of representation of standard components, symbols of pipe joints, weld joints, rivet joint etc.

DEPARTMENT: MECHANICAL ENGINEERING

LABORATORY: CSMSS/ENGG/MECH/MDCADLAB

LABORATORY MANUAL NO.:
CSMSS/ENGG/MECH/MDCAD-01

YEAR:2024-25

Class: Second Year

PART: I

SUBJECT: Machine Drawing and CAD Lab

PAGE: 3 OF 4

SURFACE FINISH SYMBOLS

R_a micrometer	Roughness Grade Numbers	Finish Marks
50	N12	
25	N11	▽
12.5	N10	
6.3	N9	▽ ▽
3.2	N8	
1.6	N7	
0.8	N6	
0.4	N5	▽ ▽ ▽
0.2	N4	
0.1	N3	
0.05	N2	▽ ▽ ▽ ▽
0.025	N1	

Machining symbol:

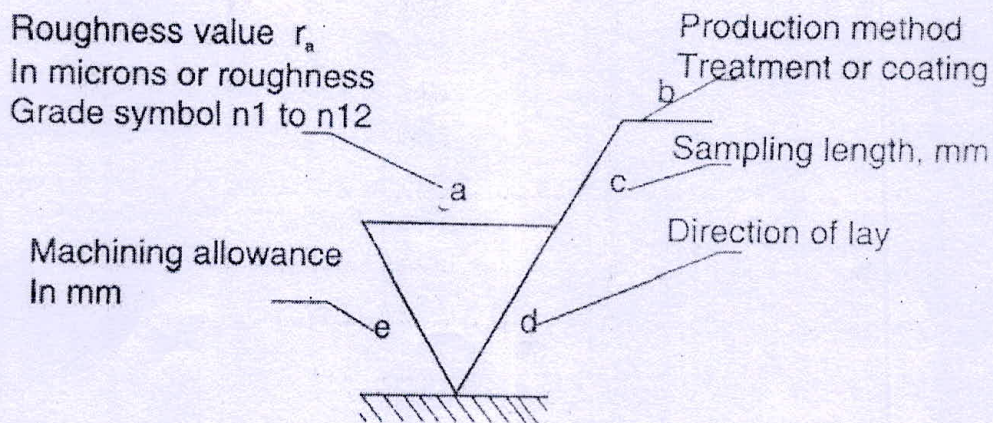

Surface Roughness Indication



PRACTICAL EXPERIMENT INSTRUCTION SHEET

EXPERIMENT TITLE: One full imperial drawing sheet consisting the drawing/sketches of representation of standard components, symbols of pipe joints, weld joints, rivet joint etc.

DEPARTMENT: MECHANICAL ENGINEERING

LABORATORY: CSMSS/ENGG/MECH/MDCADLAB

LABORATORY MANUAL NO.:
CSMSS/ENGG/MECH/MDCAD-01

YEAR:2024-25

Class: Second Year

PART: I

SUBJECT: Machine Drawing and CAD Lab

PAGE: 4 OF 4

Lay Symbol	Meaning	Example Showing Direction of Tool Marks
—	Lay approximately parallel to the line representing the surface to which the symbol is applied.	
⊥	Lay approximately perpendicular to the line representing the surface to which the symbol is applied.	
X	Lay angular in both directions to line representing the surface to which the symbol is applied.	
M	Lay multidirectional.	
C	Lay approximately circular relative to the center of the surface to which the symbol is applied.	
R	Lay approximately radial relative to the center of the surface to which the symbol is applied.	
P ³	Lay particulate, non-directional, or protuberant.	



PRACTICAL EXPERIMENT INSTRUCTION SHEET

EXPERIMENT TITLE: **Two full imperial drawing sheets, one consisting of assembly and the other consisting of details of any one standard component such as valves, components of various machine tools, pumps, joints, engine parts, etc."**

DEPARTMENT: MECHANICAL ENGINEERING

LABORATORY: CSMSS/ENGG/MECH/CAD LAB

LABORATORY MANUAL NO.:
CSMSS/ENGG/MECH/MDCAD-02

YEAR: 2024-25

Class: Second Year

PART: I

SUBJECT: MDCAD

PAGE: 1 OF 4

Aim:-

To draw Two full imperial drawing sheets, one consisting of assembly and the other consisting of details of any one standard component such as valves, components of various machine tools, pumps, joints, engine parts, etc."

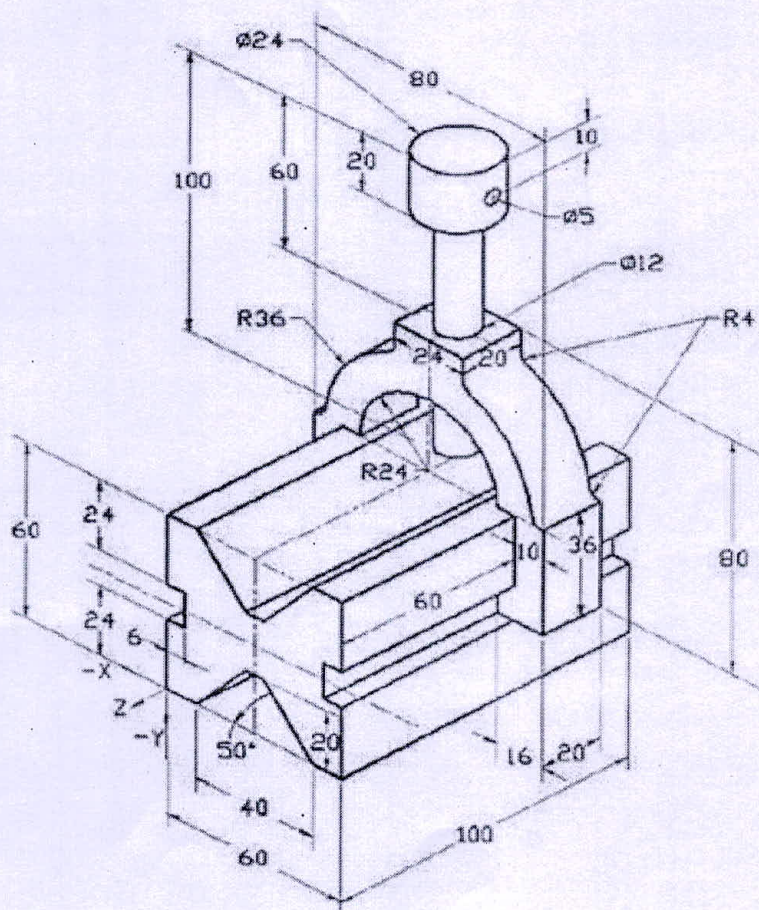

Fig.01 V-BLOCK



PRACTICAL EXPERIMENT INSTRUCTION SHEET

EXPERIMENT TITLE: **Two full imperial drawing sheets, one consisting of assembly and the other consisting of details of any one standard component such as valves, components of various machine tools, pumps, joints, engine parts, etc."**

DEPARTMENT:MECHANICAL ENGINEERING

LABORATORY: CSMSS/ENGG/MECH/CAD LAB

LABORATORY MANUAL NO.:
CSMSS/ENGG/MECH/MDCAD-02

YEAR:2024-25

Class: Second Year

PART: I

SUBJECT: MDCAD

PAGE: 2 OF 4

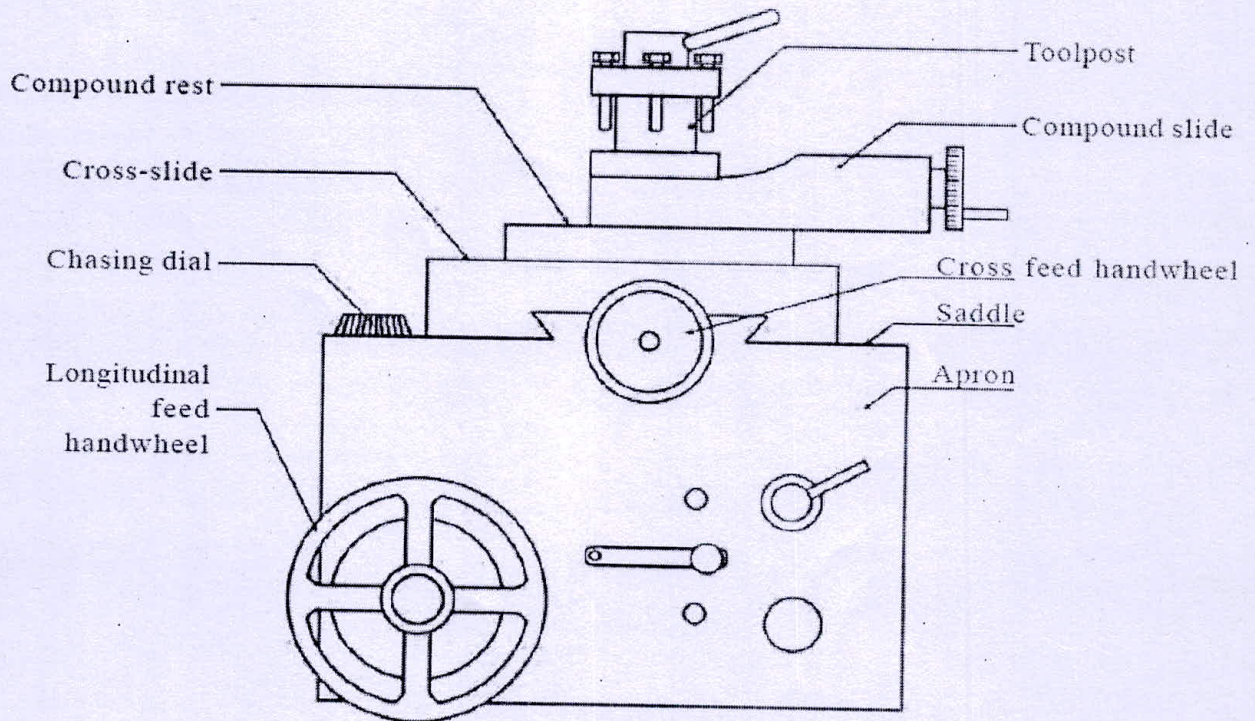

Fig.02 LATHE MACHINE CARRIAGE



PRACTICAL EXPERIMENT INSTRUCTION SHEET

EXPERIMENT TITLE: **Two full imperial drawing sheets, one consisting of assembly and the other consisting of details of any one standard component such as valves, components of various machine tools, pumps, joints, engine parts, etc."**

DEPARTMENT:MECHANICAL ENGINEERING

LABORATORY: CSMSS/ENGG/MECH/CAD LAB

LABORATORY MANUAL NO.:
CSMSS/ENGG/MECH/MDCAD-02

YEAR:2024-25

Class: Second Year

PART: I

SUBJECT: MDCAD

PAGE: 3 OF 4

DETAILS OF SCREW JACK

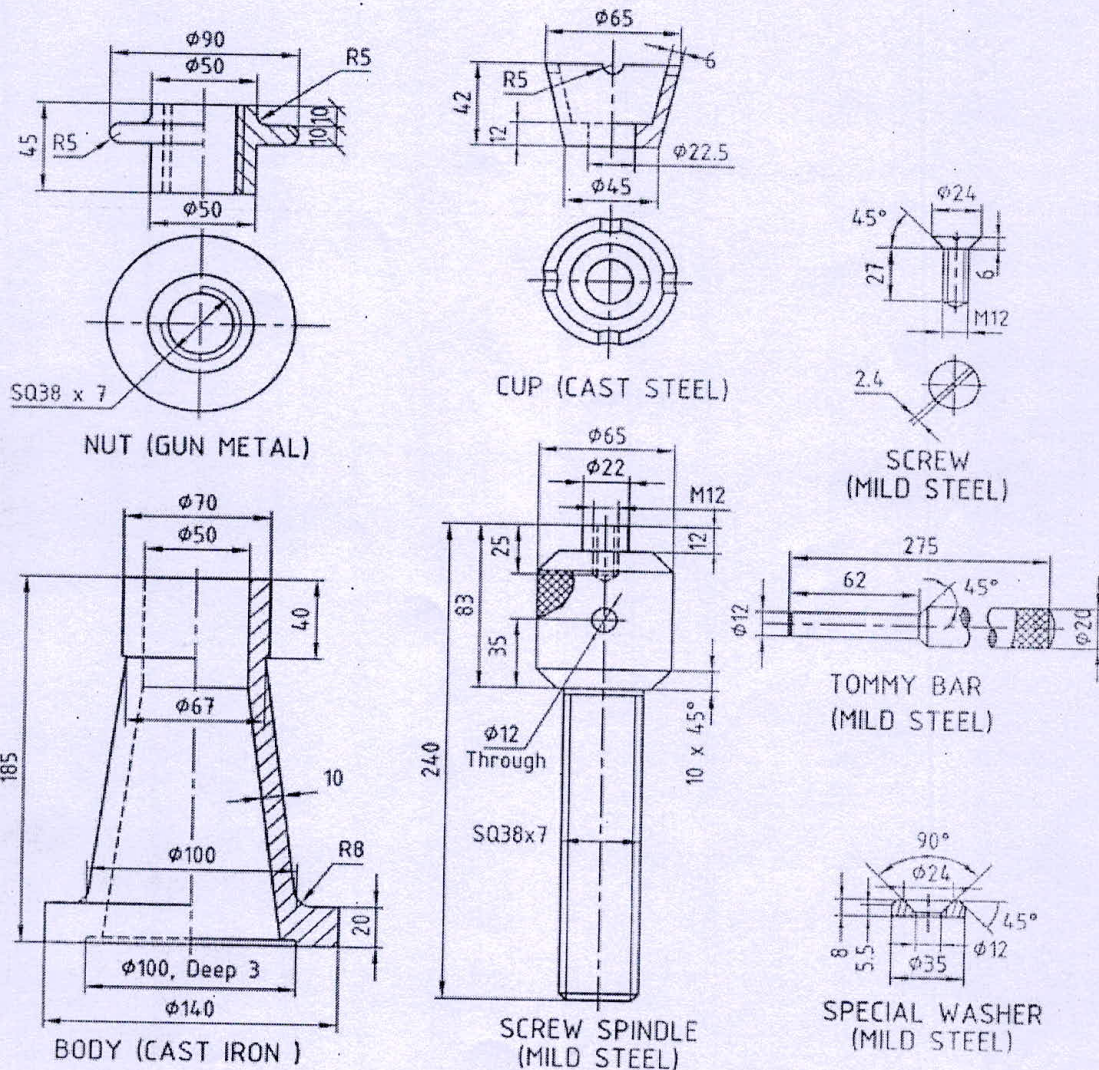

Fig-03 SREW JACK



PRACTICAL EXPERIMENT INSTRUCTION SHEET

EXPERIMENT TITLE: **Two full imperial drawing sheets, one consisting of assembly and the other consisting of details of any one standard component such as valves, components of various machine tools, pumps, joints, engine parts, etc."**

DEPARTMENT:MECHANICAL ENGINEERING

LABORATORY: CSMSS/ENGG/MECH/CAD LAB

LABORATORY MANUAL NO.:
CSMSS/ENGG/MECH/MDCAD-02

YEAR:2024-25

Class: Second Year

PART: I

SUBJECT: MDCAD

PAGE: 4 OF 4

ASSEMBLY OF SRW JACK

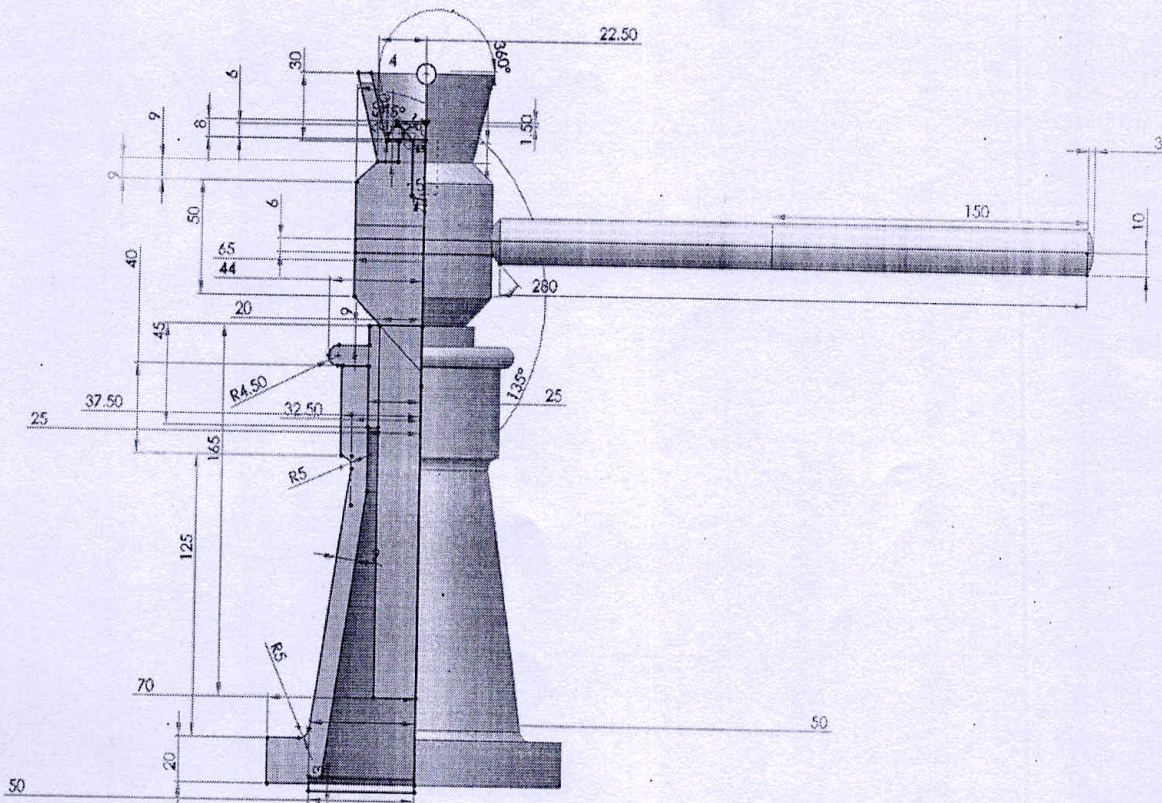

Fig-04 ASSEMBLY SREW JACK



PRACTICAL EXPERIMENT INSTRUCTION SHEET

EXPERIMENT TITLE: ". Two assignments of AutoCAD: Orthographic Projections of any one simple machine component such as bracket, Bearing Housing or Cast component for Engineers such as connecting rod, Piston, etc.; with dimensioning and detailing of three views of components."

DEPARTMENT:MECHANICAL ENGINEERING

LABORATORY: CSMSS/ENGG/MECH/CAD LAB

LABORATORY MANUAL NO.:
CSMSS/ENGG/MECH/MDCAD-03

YEAR:2024-25

Class: Second Year

PART: I

SUBJECT: MDCAD

PAGE: 1 OF 8

Aim:- To draw the orthographic projection of given parts

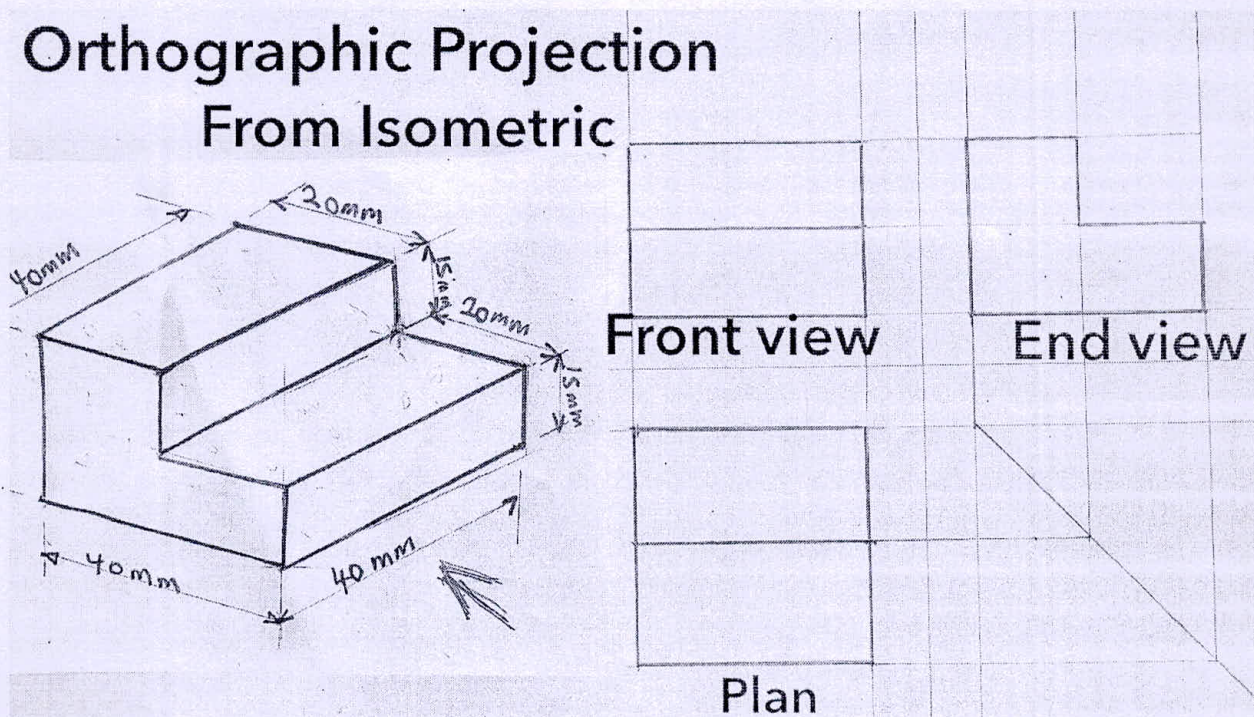

Fig-01 Orthographic from isometric view



PRACTICAL EXPERIMENT INSTRUCTION SHEET

EXPERIMENT TITLE: ". Two assignments of AutoCAD: Orthographic Projections of any one simple machine component such as bracket, Bearing Housing or Cast component for Engineers such as connecting rod, Piston, etc.; with dimensioning and detailing of three views of components."

DEPARTMENT:MECHANICAL ENGINEERING

LABORATORY: CSMSS/ENGG/MECH/CAD LAB

LABORATORY MANUAL NO.:
CSMSS/ENGG/MECH/MDCAD-03

YEAR:2024-25

Class: Second Year

PART: I

SUBJECT: MDCAD

PAGE: 2 OF 8

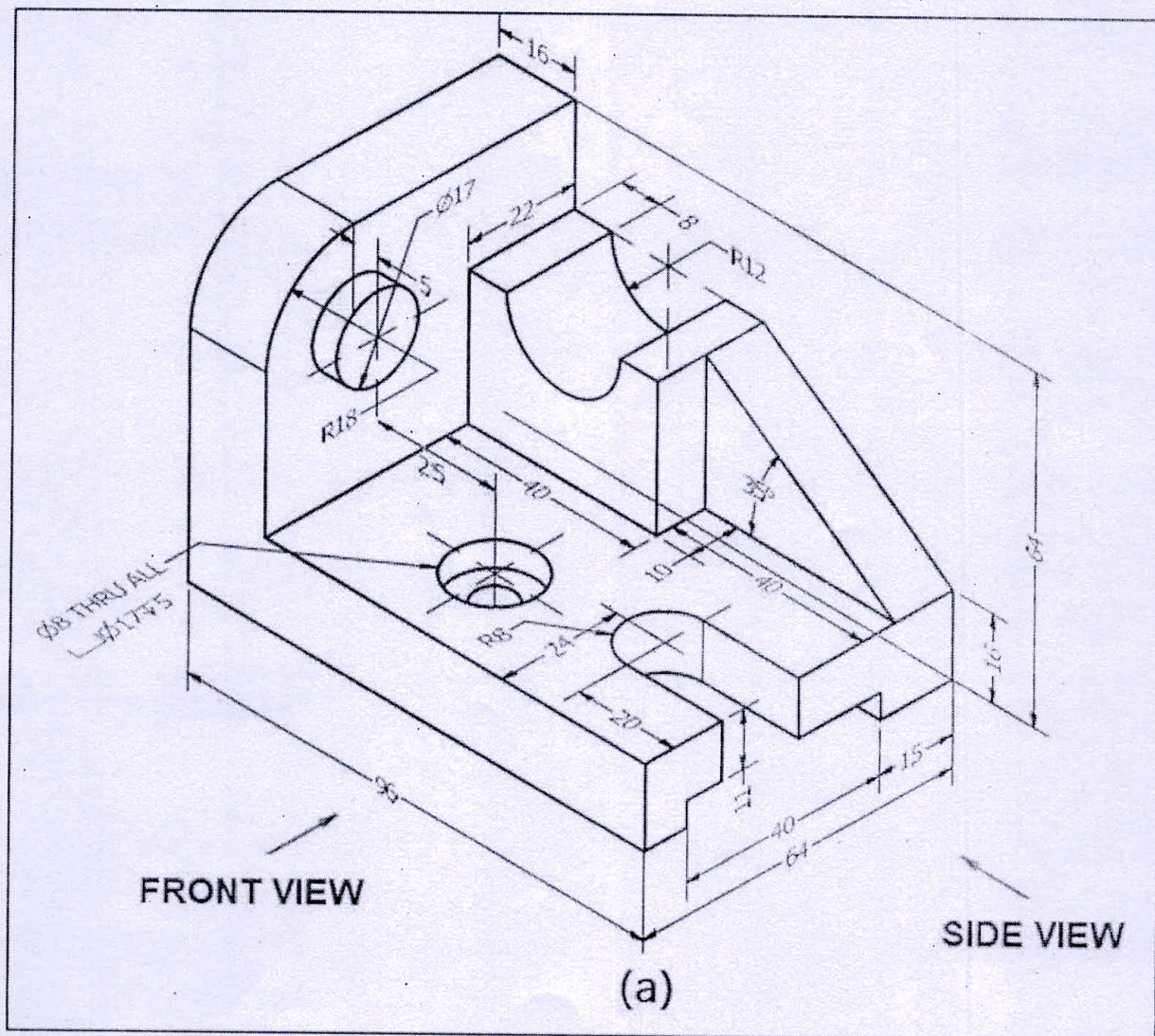

Figure 2

Fig-01 isometric view from Orthographic



PRACTICAL EXPERIMENT INSTRUCTION SHEET

EXPERIMENT TITLE: ". Two assignments of AutoCAD: Orthographic Projections of any one simple machine component such as bracket, Bearing Housing or Cast component for Engineers such as connecting rod, Piston, etc.; with dimensioning and detailing of three views of components."

DEPARTMENT:MECHANICAL ENGINEERING

LABORATORY: CSMSS/ENGG/MECH/CAD LAB

LABORATORY MANUAL NO.:
CSMSS/ENGG/MECH/MDCAD-03

YEAR:2024-25

Class: Second Year

PART: I

SUBJECT: MDCAD

PAGE: 3 OF 8

ORTHOGRAPHIC PROJECTIONS

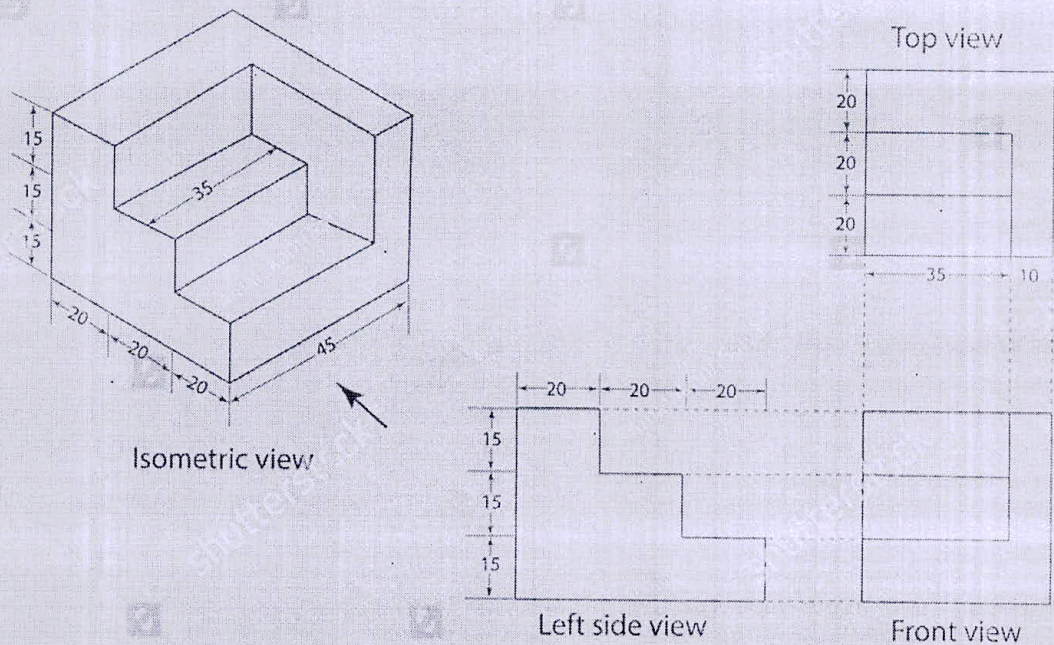

shutterstock

IMAGE ID: 104681633
WWW.SHUTTERSTOCK.COM

Fig-03 Orthographic from isometric view



PRACTICAL EXPERIMENT INSTRUCTION SHEET

EXPERIMENT TITLE: ". Two assignments of AutoCAD: Orthographic Projections of any one simple machine component such as bracket, Bearing Housing or Cast component for Engineers such as connecting rod, Piston, etc.; with dimensioning and detailing of three views of components."

DEPARTMENT:MECHANICAL ENGINEERING

LABORATORY: CSMSS/ENGG/MECH/CAD LAB

LABORATORY MANUAL NO.:
CSMSS/ENGG/MECH/MDCAD-03

YEAR:2024-25

Class: Second Year

PART: I

SUBJECT: MDCAD

PAGE: 4 OF 8

Orthographic Projection

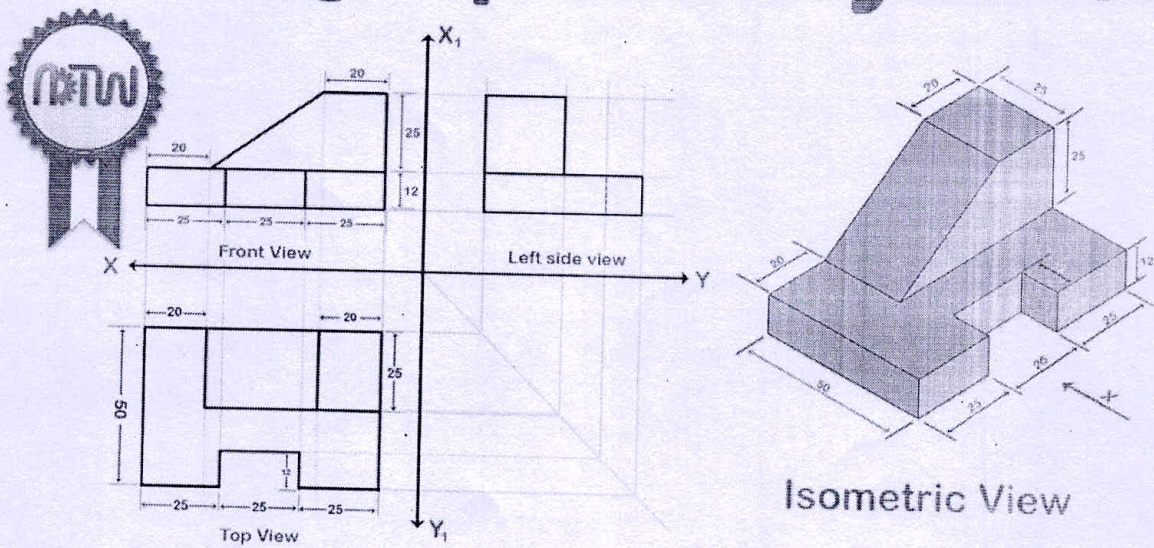
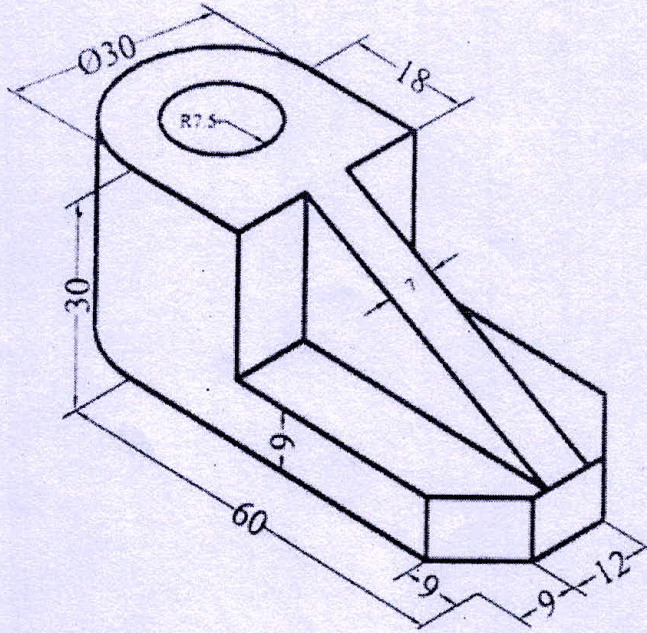

Fig-04 Orthographic from isometric view



CHH.SHAHU COLLEGE OF ENGINEERING
DEPARTMENT OF MECHANICAL ENGINEERING

Q.1 Draw Orthographic Projection of given Component





PRACTICAL EXPERIMENT INSTRUCTION SHEET

EXPERIMENT TITLE: ". Two assignments of AutoCAD: Orthographic Projections of any one simple machine component such as bracket, Bearing Housing or Cast component for Engineers such as connecting rod, Piston, etc.; with dimensioning and detailing of three views of components."

DEPARTMENT:MECHANICAL ENGINEERING

LABORATORY: CSMSS/ENGG/MECH/CAD LAB

LABORATORY MANUAL NO.:
CSMSS/ENGG/MECH/MDCAD-03

YEAR:2024-25

Class: Second Year

PART: I

SUBJECT: MDCAD

PAGE: 5 OF 8

EXERCISE-01 2D-Drawing

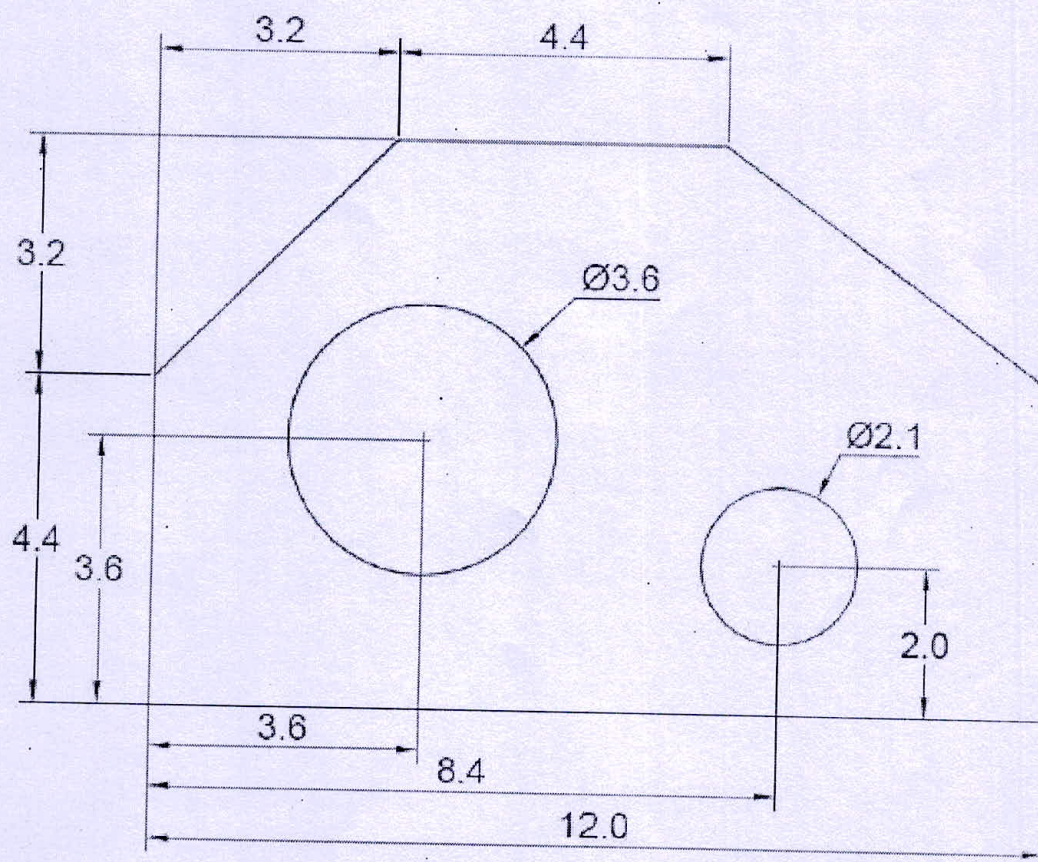

Fig-01



PRACTICAL EXPERIMENT INSTRUCTION SHEET

EXPERIMENT TITLE: ". Two assignments of AutoCAD: Orthographic Projections of any one simple machine component such as bracket, Bearing Housing or Cast component for Engineers such as connecting rod, Piston, etc.; with dimensioning and detailing of three views of components."

DEPARTMENT:MECHANICAL ENGINEERING

LABORATORY: CSMSS/ENGG/MECH/CAD LAB

LABORATORY MANUAL NO.:
CSMSS/ENGG/MECH/MDCAD-03

YEAR:2024-25

Class: Second Year

PART: I

SUBJECT: MDCAD

PAGE: 6 OF 8

EXERCISE-02 and 03 , 2D-Drawing Fig-02

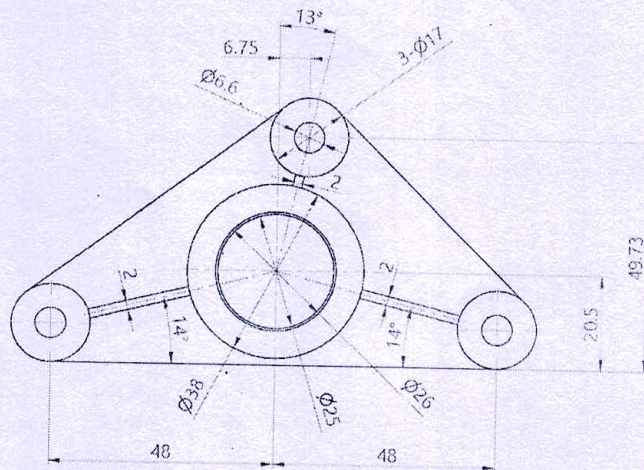
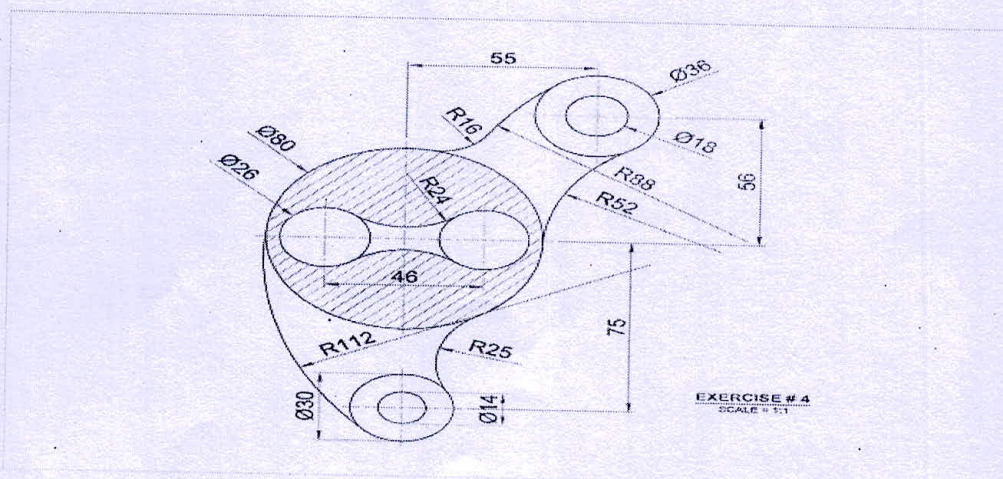

Fig-03





PRACTICAL EXPERIMENT INSTRUCTION SHEET

EXPERIMENT TITLE: ". Two assignments of AutoCAD: Orthographic Projections of any one simple machine component such as bracket, Bearing Housing or Cast component for Engineers such as connecting rod, Piston, etc.; with dimensioning and detailing of three views of components."

DEPARTMENT:MECHANICAL ENGINEERING		LABORATORY: CSMSS/ENGG/MECH/CAD LAB	
LABORATORY MANUAL NO.: CSMSS/ENGG/MECH/MDCAD-03		YEAR:2024-25	
Class: Second Year	PART: I	SUBJECT: MDCAD	PAGE: 7 OF 8

EXERCISE-04 2D-Drawing

Fig-04

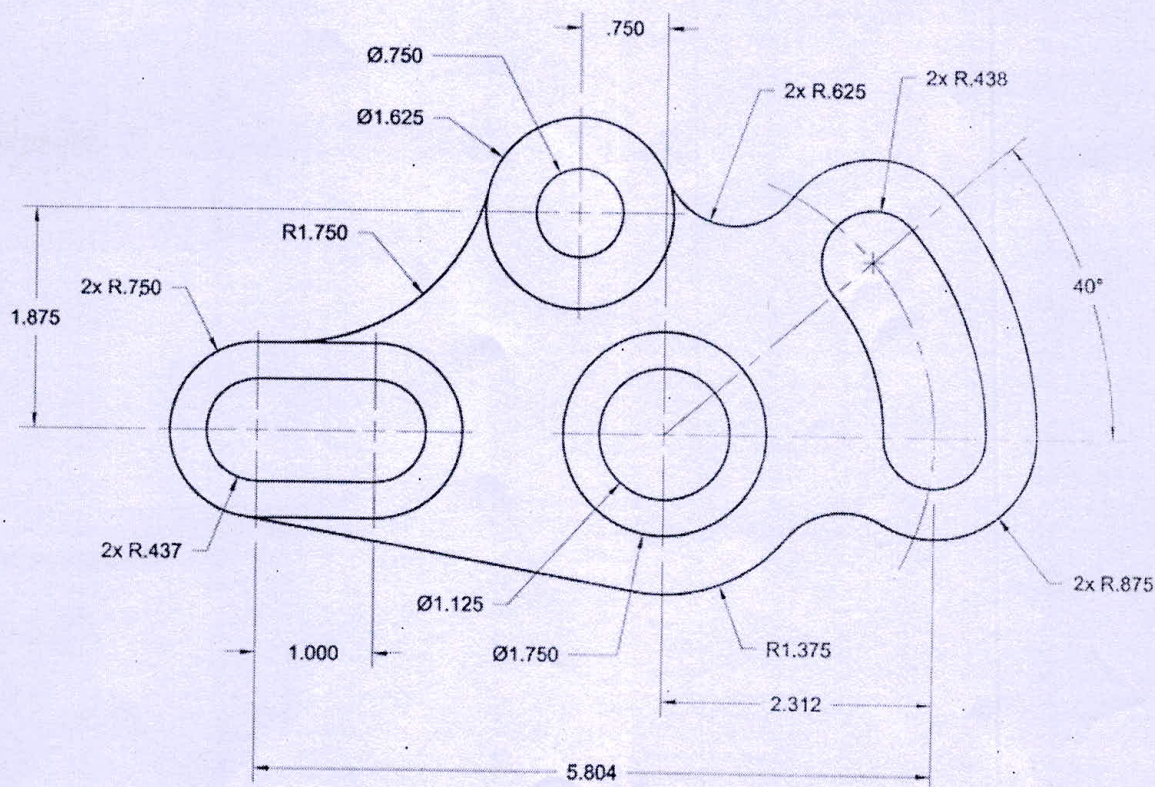

Theory:



DEPARTMENT:MECHANICAL ENGINEERING

LABORATORY: CSMSS/ENGG/MECH/CAD LAB

LABORATORY MANUAL NO.:
CSMSS/ENGG/MECH/MDCAD-04

YEAR:2024-25

Class: Second Year

PART: I

SUBJECT: MDCAD

PAGE: 1 OF 36

Aim: - To draw one 3-D Model of simple machine component.

3D Modeling of Simple Machine Parts

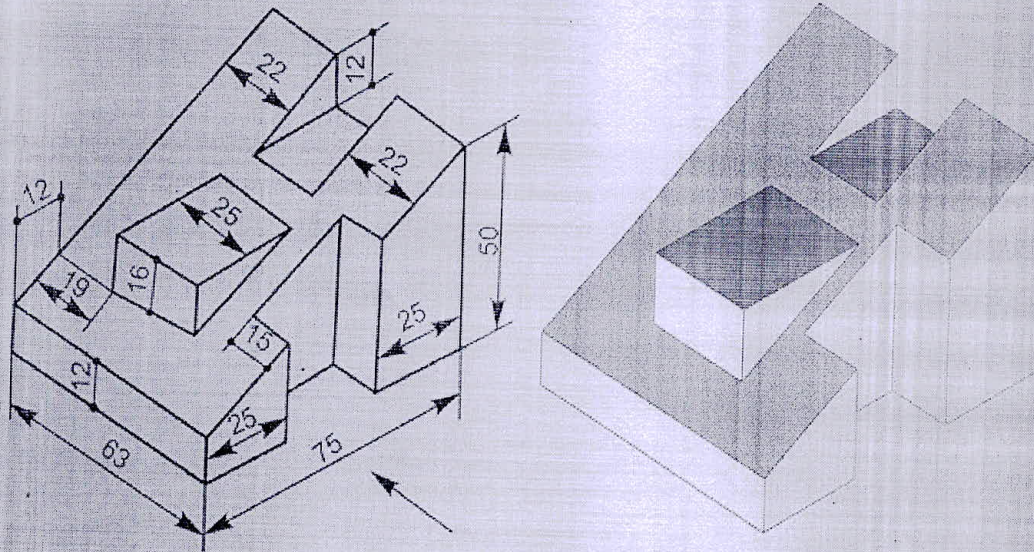

Fig-01



PRACTICAL EXPERIMENT INSTRUCTION SHEET

EXPERIMENT TITLE -3-D model at least one simple machine component.

DEPARTMENT:MECHANICAL ENGINEERING		LABORATORY: CSMSS/ENGG/MECH/CAD LAB	
LABORATORY MANUAL NO.: CSMSS/ENGG/MECH/MDCAD-04		YEAR:2024-25	
Class: Second Year	PART: I	SUBJECT: MDCAD	PAGE: 2 OF 36

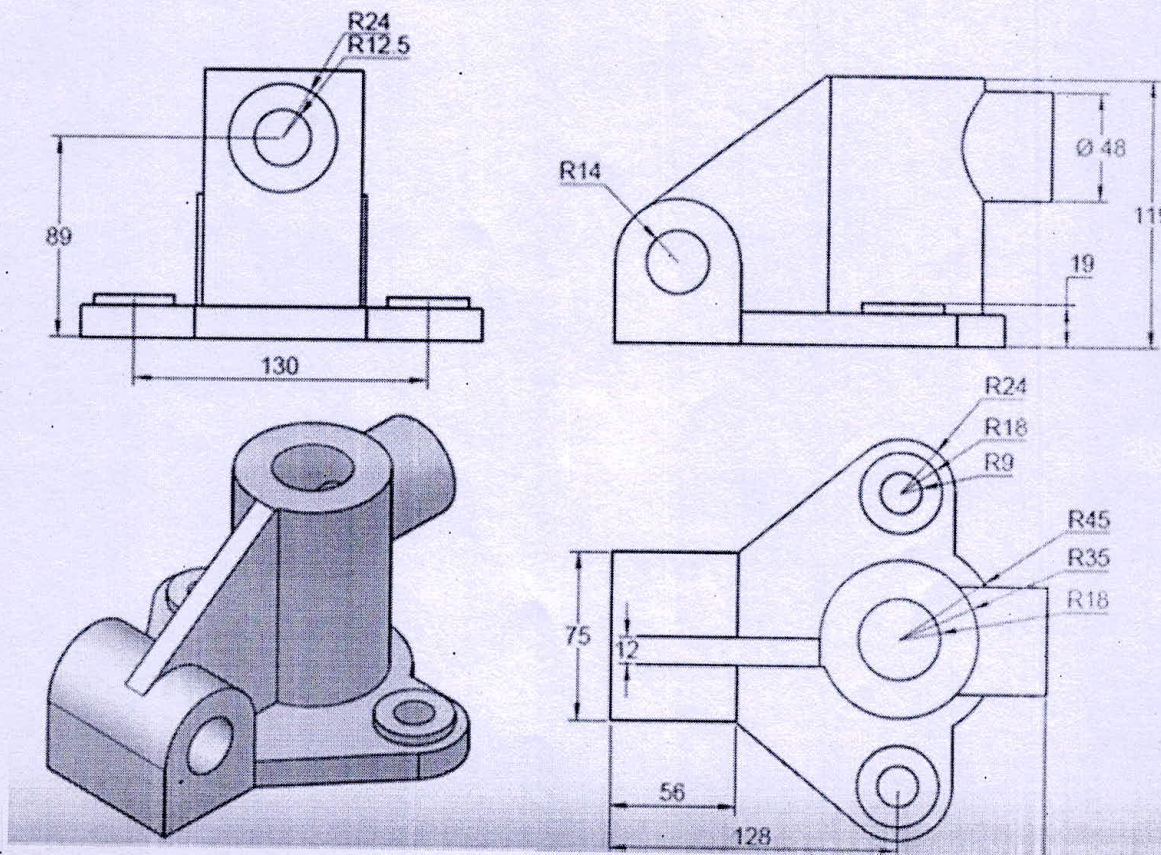



Fig-02

	CHH. SHAHU COLLEGE OF ENGINEERING, AURANGABAD		LABORATORY MANUAL
	PRACTICAL EXPERIMENT INSTRUCTION SHEET		
	EXPERIMENT TITLE -3-D model at least one simple machine component.		
DEPARTMENT:MECHANICAL ENGINEERING		LABORATORY: CSMSS/ENGG/MECH/CAD LAB	
LABORATORY MANUAL NO.: CSMSS/ENGG/MECH/MDCAD-04		YEAR:2024-25	
Class: Second Year	PART: I	SUBJECT: MDCAD	PAGE: 3 OF 36

S.No	CONTENTS	PAGE NO
1	Introduction to CAD	
2	ACAD – Basics	
3	2 - D Figures Using ACAD	
4	Isometric Drawings Using ACAD	
5	3-D Figures Using ACAD	
6	Introduction to CREO 3.0	
7	Exercises on CREO 3.0	

INTRODUCTION to CAD

Prepared by- Prof. B.M. Netake

HOD- Dr.R.H.Shinde

	CHH. SHAHU COLLEGE OF ENGINEERING, AURANGABAD		LABORATORY MANUAL
	PRACTICAL EXPERIMENT INSTRUCTION SHEET		
	EXPERIMENT TITLE -3-D model at least one simple machine component.		
DEPARTMENT:MECHANICAL ENGINEERING		LABORATORY: CSMSS/ENGG/MECH/CAD LAB	
LABORATORY MANUAL NO.: CSMSS/ENGG/MECH/MDCAD-04		YEAR:2024-25	
Class: Second Year	PART: I	SUBJECT: MDCAD	PAGE: 4 OF 36

AutoCAD – BASICS

- 1.Starting with AutoCAD
- 2.Layout and sketching
- 3.Drawing environment
- 4.Elements of drawing
- 5.Draw commands
- 6:3D functions
7. 2D – FIGURES for practice USING Auto CAD 2017/23
8. ISOMETRIC DRAWING for practice USING AutoCAD2013
9. 3-D SOLID FIGURES USING ACAD 2013

INTRODUCTION TO CREO 3.0

Learning Different Operations like Threading, Sweep, Swept blend.

Modeling

Assembling

Equipment needed: Computers and Software: AutoCAD 2017/23

Reference Books:

1. Engineering graphics with Auto CAD- R.B. Choudary/Anuradha Publishes

Outcomes:

- Ability to use the software packers for drafting and modeling
- Ability to create 2D and 3D models of Engineering Component

	CHH. SHAHU COLLEGE OF ENGINEERING, AURANGABAD		LABORATORY MANUAL
	PRACTICAL EXPERIMENT INSTRUCTION SHEET		
	EXPERIMENT TITLE -3-D model at least one simple machine component.		
DEPARTMENT:MECHANICAL ENGINEERING		LABORATORY: CSMSS/ENGG/MECH/CAD LAB	
LABORATORY MANUAL NO.: CSMSS/ENGG/MECH/MDCAD-04		YEAR:2024-25	
Class: Second Year	PART: I	SUBJECT: MDCAD	PAGE: 5 OF 36

1. INTRODUCTION

Computer Aided Drafting is a process of preparing a drawing of an object on the screen of a computer. There are various types of drawings in different fields of engineering and sciences. In the fields of mechanical or aeronautical engineering, the drawings of machine components and the layouts of them are prepared. In the field of civil engineering, plans and layouts of the buildings are prepared. In the field of electrical engineering, the layouts of power distribution system are prepared. In all fields of engineering use of computer is made for drawing and drafting.

The use of CAD process provides enhanced graphics capabilities which allows any designerto

- Conceptualize his ideas
- Modify the design very easily
- Perform animation
- Make design calculations
- Use colors, fonts and other aesthetic features.

REASONS FOR IMPLEMENTING A CAD SYSTEM

1. **Increases the productivity of the designer:** CAD improves the productivity of the designer to visualize the product and its component, parts and reduces the time required in synthesizing, analyzing and documenting the design
2. **Improves the quality of the design:** CAD system improves the quality of

	CHH. SHAHU COLLEGE OF ENGINEERING, AURANGABAD		LABORATORY MANUAL
	PRACTICAL EXPERIMENT INSTRUCTION SHEET		
	EXPERIMENT TITLE -3-D model at least one simple machine component.		
DEPARTMENT:MECHANICAL ENGINEERING		LABORATORY: CSMSS/ENGG/MECH/CAD LAB	
LABORATORY MANUAL NO.: CSMSS/ENGG/MECH/MDCAD-04		YEAR:2024-25	
Class: Second Year	PART: I	SUBJECT: MDCAD	PAGE: 6 OF 36

the design. A CAD system permits a more detailed engineering analysis and a larger number of design alternatives can be investigated. The design errors are also reduced because of the greater accuracy provided by the system

3. **Improves communication:** It improves the communication in design. The use of a CAD system provides better engineering drawings, more standardization in the drawing, better documentation of the design, few drawing errors and legibility.
4. **Create data base for manufacturing:** In the process of creating the documentation for these products, much of the required data base to manufacture the products is also created.
5. **Improves the efficiency of the design:** It improves the efficiency of the design process and the wastage at the design stage can be reduced.

APPLICATION OF CAD:

There are various processes which can be performed by use of computer in the drafting process.

1. **Automated drafting:** This involves the creation of hard copy engineering drawings directly from CAD data base. Drafting also includes features like automatic dimensioning, generation of cross – hatched areas, scaling of the drawing and the capability to develop sectional views and enlarged views in detail. It has ability to perform transformations of images and prepare 3D drawings like isometric views, perspective views etc.,

	CHH. SHAHU COLLEGE OF ENGINEERING, AURANGABAD		LABORATORY MANUAL
	PRACTICAL EXPERIMENT INSTRUCTION SHEET		
	EXPERIMENT TITLE -3-D model at least one simple machine component.		
DEPARTMENT:MECHANICAL ENGINEERING		LABORATORY: CSMSS/ENGG/MECH/CAD LAB	
LABORATORY MANUAL NO.: CSMSS/ENGG/MECH/MDCAD-04		YEAR:2024-25	
Class: Second Year	PART: I	SUBJECT: MDCAD	PAGE: 7 OF 36

2. **Geometric modeling:** concerned with the computer compatible mathematical description of the geometry of an object. The mathematical description allows the image of an object to be displayed and manipulated on a graphics terminal through signals from the CPU of the CAD system. The software that provides geometric modeling capabilities must be designed for efficient use both by computer and the human designer.

BENEFITS OF CAD:

The implementation of the CAD system provides variety of benefits to the industries in design and production as given below:

1. Improved productivity in drafting
2. Shorter preparation time for drawing
3. Reduced man power requirement
4. Customer modifications in drawing are easier
5. More efficient operation in drafting
6. Low wastage in drafting
7. Minimized transcription errors in drawing
8. Improved accuracy of drawing
9. Assistance in preparation of documentation
10. Better designs can be evolved
11. Colours can be used to customize the product
12. Production of orthographic projections with dimensions and tolerances
13. Hatching of all sections with different filling pattern

	CHH. SHAHU COLLEGE OF ENGINEERING, AURANGABAD		LABORATORY MANUAL
	PRACTICAL EXPERIMENT INSTRUCTION SHEET		
	EXPERIMENT TITLE -3-D model at least one simple machine component.		
DEPARTMENT:MECHANICAL ENGINEERING		LABORATORY: CSMSS/ENGG/MECH/CAD LAB	
LABORATORY MANUAL NO.: CSMSS/ENGG/MECH/MDCAD-04		YEAR:2024-25	
Class: Second Year	PART: I	SUBJECT: MDCAD	PAGE: 8 OF 36

CAD SOFTWARES

The software is an interpreter or translator which allows the user to perform specific type of application or job related to CAD. The following software's are available for drafting.

1. AUTOCAD
2. Pro – E
3. CATIA
4. MS OFFICE
5. PAINT
6. ANSYS
7. MSc.NASTRAN
8. IDEAS
9. SOLID WORKS
10. HYPERMESH
11. FLUENT – GAMBIT

The above software is used depending upon their application.

AUTO CAD

Auto CAD package is suitable for accurate and perfect drawings of engineering designs. The drawing of machine parts, isometric views and assembly drawings are possible in AutoCAD. The package is suitable for 2D and 3D drawings.

	CHH. SHAHU COLLEGE OF ENGINEERING, AURANGABAD		LABORATORY MANUAL
	PRACTICAL EXPERIMENT INSTRUCTION SHEET EXPERIMENT TITLE -3-D model at least one simple machine component.		
DEPARTMENT:MECHANICAL ENGINEERING		LABORATORY: CSMSS/ENGG/MECH/CAD LAB	
LABORATORY MANUAL NO.: CSMSS/ENGG/MECH/MDCAD-04		YEAR:2024-25	
Class: Second Year	PART: I	SUBJECT: MDCAD	PAGE: 9 OF 36

AutoCAD – BASICS

1. STARTING WITH ACAD

CAD uses four basic elements for preparation of any drawing:

2. Line
3. Curves
4. Text
5. Filling point.

Computer Aided Drafting is done by the operator by placing the mouse pointer by placing the mouse pointer at the desired location and then executing the command to draw the graphic elements using different methods.

Advanced computer aided drafting packages utilize four areas on the screen.

1. Drawing Area
2. Command Area
3. Menu Area
4. CAD LAB MANUAL Tool boxes.

	CHH. SHAHU COLLEGE OF ENGINEERING, AURANGABAD		LABORATORY MANUAL
	PRACTICAL EXPERIMENT INSTRUCTION SHEET		
	EXPERIMENT TITLE -3-D model at least one simple machine component.		
DEPARTMENT:MECHANICAL ENGINEERING		LABORATORY: CSMSS/ENGG/MECH/CAD LAB	
LABORATORY MANUAL NO.: CSMSS/ENGG/MECH/MDCAD-04		YEAR:2024-25	
Class: Second Year	PART: I	SUBJECT: MDCAD	PAGE: 10 OF 36

2.1 LAYOUT AND SKETCHING

The package provides various facilities for layout, sketching and borders for preparing a drawing. It provides facilities for display coordinates and measurement units.

- a. **Units:** The format for display co – ordinates and measurement can be selected according to the requirement. Several measurement styles are available in ACAD. The main methods are engineering and architectural, having specific base unit assigned to them.
- i. Decimal: select to enter and display measurements in decimal notation
 - ii. Engineering: Display measurements in feet and decimal inches.
 - iii. Architectural: Display measurements in feet, inches and fractional inches
 - iv. Fractional: Display measurements in mixed numbers notation
 - v. Scientific: Display measurements in scientific notation.

The precision that is specified controls the number of decimal places or fractional size to which we want linear measurements displayed.

- b. **Angles:** Select the format in which we want to enter and display angles.
- i. Decimal Degrees: Display partial degrees as decimals
 - ii. Deg/Min/Sec: Display partial degrees as minutes and seconds.
 - iii. Grades: Display Angles as grades
 - iv. Radians: Display angles as radians.
 - v. Surveyor: Displays angles in surveyor units.
- c. **Angle measure:** Select the direction of the zero angle for the entry of angles:

	CHH. SHAHU COLLEGE OF ENGINEERING, AURANGABAD		LABORATORY MANUAL
	PRACTICAL EXPERIMENT INSTRUCTION SHEET		
	EXPERIMENT TITLE -3-D model at least one simple machine component.		
DEPARTMENT:MECHANICAL ENGINEERING		LABORATORY: CSMSS/ENGG/MECH/CAD LAB	
LABORATORY MANUAL NO.: CSMSS/ENGG/MECH/MDCAD-04		YEAR:2024-25	
Class: Second Year	PART: I	SUBJECT: MDCAD	PAGE: 11 OF 36

- i. East: Select to specify the compass direction east as the zero angle.
- ii. North: Select to specify the compass direction north as the zero angle.
- iii. West: Select to specify the compass direction west as the zero angle.
- iv. South: Select to specify the compass direction south as the zero angle.
- v Other: Select to specify a direction different from the points of the compass

d. **Area:** Enter the approximate width and length which is planned to draw in full scale units. This limits the area of the drawing covered by grid dots when the grid is turned on. It also adjusts several default settings, such as text height, line etc.

LIMITS

This sets and controls the drawing boundaries. At the command prompt, enter **limits**

ON/OFF/<LOWER LEFT CORNER> <current>: Specify a point, enter **on** or **off**, or press

enter. LTSCALE

This sets the line type scale factor. Use LTSCALE to change the relative length of the dash – dot line types per drawing unit

At the Command prompt, enter **ltscale**

	CHH. SHAHU COLLEGE OF ENGINEERING, AURANGABAD		LABORATORY MANUAL
	PRACTICAL EXPERIMENT INSTRUCTION SHEET		
	EXPERIMENT TITLE -3-D model at least one simple machine component.		
DEPARTMENT:MECHANICAL ENGINEERING		LABORATORY: CSMSS/ENGG/MECH/CAD LAB	
LABORATORY MANUAL NO.: CSMSS/ENGG/MECH/MDCAD-04		YEAR:2024-25	
Class: Second Year	PART: I	SUBJECT: MDCAD	PAGE: 12 OF 36

New scale factor <current> : Enter a positive real value or press enter

Changing the line type scale factor causes the drawing to regenerate.

MEASURE

This places point objects or blocks at measured intervals on an object. At the command prompt, enter **measure**

Select object to measure: Use an object selection method <segment length> / Block: Specify a distance.

PAN

This moves the drawing display in the current viewport. At the command prompt , enter **pan**

Displacement: Specify a point (1)

The point which specify indicates the amount to move the drawing or the location of the drawing to be moved.

Second point: Press or specify a point (2)

If pressed, ACAD moves the drawing by the amount which is specified in the Displacement prompt. If we specify a point, ACAD moves the location of the drawing to that point.

	CHH. SHAHU COLLEGE OF ENGINEERING, AURANGABAD		LABORATORY MANUAL
	PRACTICAL EXPERIMENT INSTRUCTION SHEET		
	EXPERIMENT TITLE -3-D model at least one simple machine component.		
DEPARTMENT:MECHANICAL ENGINEERING		LABORATORY: CSMSS/ENGG/MECH/CAD LAB	
LABORATORY MANUAL NO.: CSMSS/ENGG/MECH/MDCAD-04		YEAR:2024-25	
Class: Second Year	PART: 1	SUBJECT: MDCAD	PAGE: 13 OF 36

2.2 ELEMENTS OF DRAWING

2.2.1 DRAW

COMMANDS

LINE:

A line is specified by giving its two end points or first point and the distance of line along with its angle of inclination. A line can be drawn by using two commands.

Command: **line**

Specify first point: Specify a point (1)

Specify next point or [Undo]:

Specify a point (2) The second point can be indicated by **@d<a**

Where **d** is the distance of line and **a** is the angle of inclination in degrees.

PLINE:

This is a poly line which allows continuous segment of the line and it is drawn similar to the line command. The polyline allows changing the thickness of the line according to the requirement.

From the Draw tool bar choose the Polyline flyout. Draw pull down menu:

	CHH. SHAHU COLLEGE OF ENGINEERING, AURANGABAD		LABORATORY MANUAL
	PRACTICAL EXPERIMENT INSTRUCTION SHEET		
	EXPERIMENT TITLE -3-D model at least one simple machine component.		
DEPARTMENT:MECHANICAL ENGINEERING		LABORATORY: CSMSS/ENGG/MECH/CAD LAB	
LABORATORY MANUAL NO.: CSMSS/ENGG/MECH/MDCAD-04		YEAR:2024-25	
Class: Second Year	PART: I	SUBJECT: MDCAD	PAGE: 14 OF 36

Polyline

At the command
prompt, enter **pline**

Syntax

Specify start point: Specify a point (1)

Current line-width

is <current>

Specify next point or [Arc/Close/Halfwidth/Length/Undo/Width]: Specify
a point (2) or enter an option

LINETYPE

Creates, loads, and sets linetypes. The LINETYPE command defines line
characteristics consisting of dashes, dots, and spaces.

Format menu: Linetype or Command line: linetype

1. CURVES

Following are the various types of curves used in the drawings:

- i. Circle
- ii. Ellipse
- iii. Arc
- iv. Regular or any other type.

	CHH. SHAHU COLLEGE OF ENGINEERING, AURANGABAD		LABORATORY MANUAL
	PRACTICAL EXPERIMENT INSTRUCTION SHEET		
	EXPERIMENT TITLE -3-D model at least one simple machine component.		
DEPARTMENT:MECHANICAL ENGINEERING		LABORATORY: CSMSS/ENGG/MECH/CAD LAB	
LABORATORY MANUAL NO.: CSMSS/ENGG/MECH/MDCAD-04		YEAR:2024-25	
Class: Second Year	PART: I	SUBJECT: MDCAD	PAGE: 15 OF 36

i. **Circle:** The circle can be drawn by using two types of commands

a. **Circle**

b. **Donut**

a. **CIRCLE:** This command draws the circle by using four methods:

b. **CIRCLE:** This command draws the circle by using four methods:

i. Center point and radius

ii. Two point circle

iii. Three point circle

iv. Tangent circle

At the command prompt, enter **circle**

Specify center point for circle or [3P (Three Points)/2P (Two Points)/Ttr]: Specify a point or enter an option

c. **DONUT:** This draws filled circles and rings.

Donuts are constructed of a closed polyline composed of wide arc segments. At the command prompt, enter **donut**

Specify inside diameter of donut <current>: Specify a distance or press ENTER

If you specify an inside diameter of 0, the donut is a filled circle.

Specify outside diameter of donut <current>: Specify a distance or press ENTER

Specify center of donut or <exit>: Specify a point (1) or press ENTER to end the command

ii. **ELLIPSE:** It is a curve having major and minor axis with a center.

	CHH. SHAHU COLLEGE OF ENGINEERING, AURANGABAD		LABORATORY MANUAL
	PRACTICAL EXPERIMENT INSTRUCTION SHEET		
	EXPERIMENT TITLE -3-D model at least one simple machine component.		
DEPARTMENT:MECHANICAL ENGINEERING		LABORATORY: CSMSS/ENGG/MECH/CAD LAB	
LABORATORY MANUAL NO.: CSMSS/ENGG/MECH/MDCAD-04		YEAR:2024-25	
Class: Second Year	PART: I	SUBJECT: MDCAD	PAGE: 16 OF 36

The ellipse can be prepared by four methods.

Axis
endpoint
Arc
Centre

ELLIPSE

Creates an ellipse or an elliptic arc.

Axis end point: Defines the first axis by two specified endpoints. The angle of the first axis determines the angle of the ellipse. The first axis can define either the major or the minor axis of the ellipse.

Arc: Creates an elliptical arc. The angle of the first axis determines the angle of the elliptical arc. The first axis can define either the major or the minor axis of the elliptical arc.

Center: Creates the ellipse by a specified center point.

Isocircle: Creates an isometric circle in the current isometric drawing plane.

At the command prompt, enter **ellipse**

- iii. **Arc:** The arc is a curve specified by center and radius as well as the start angle and end angle . There are seven method used for drawing an arc.
 1. Three point method
 2. Start point-center point –end point

	CHH. SHAHU COLLEGE OF ENGINEERING, AURANGABAD		LABORATORY MANUAL
	PRACTICAL EXPERIMENT INSTRUCTION SHEET		
	EXPERIMENT TITLE -3-D model at least one simple machine component.		
DEPARTMENT:MECHANICAL ENGINEERING		LABORATORY: CSMSS/ENGG/MECH/CAD LAB	
LABORATORY MANUAL NO.: CSMSS/ENGG/MECH/MDCAD-04		YEAR:2024-25	
Class: Second Year	PART: I	SUBJECT: MDCAD	PAGE: 17 OF 36

3. Start point-center point-length of chord
4. Start point-end point –angle of inclusion
5. Start point-end point-direction
6. Start point-center point-angle of inclusion
7. Start point-end point-radius

These methods can be used by executing the arc command

- ARC:** creates an arc.

At the command prompt, enter arc

Center/<start point>: specify a point, enter c, or press enter

- Polyarc:** the second method of the drawing the arc is poly arc by use of pline command. This command allows drawing of filled arc of any width .it also allows for drawing of a regular or irregular curve.

2. Drawing of Rectangle: A rectangle can be drawn by LINE command or by Rectangle command. The **PLINE** command also allows for drawing of hollow or filled rectangle .A **SOLID** command is also used for drawing of filled rectangles.

1. **RECTANGLES:** draws a rectangular polyline At the command prompt, enter **rectangle**
First corner: specify point (1) Other corner: specify point (2)
2. **SOLID:** creates solid –filled polygons .solids are filled only when fill system variable is set to on view is set to plan.

At the command prompt, enter **solid**

First corner: specify point (1) Other corner: specify point (2)

	CHH. SHAHU COLLEGE OF ENGINEERING, AURANGABAD		LABORATORY MANUAL
	PRACTICAL EXPERIMENT INSTRUCTION SHEET		
	EXPERIMENT TITLE -3-D model at least one simple machine component.		
DEPARTMENT:MECHANICAL ENGINEERING		LABORATORY: CSMSS/ENGG/MECH/CAD LAB	
LABORATORY MANUAL NO.: CSMSS/ENGG/MECH/MDCAD-04		YEAR:2024-25	
Class: Second Year	PART: I	SUBJECT: MDCAD	PAGE: 18 OF 36

The first two points define one edge of the polygon.

Third point: specify a point (3) diagonally opposite the second Forth point: specify a point (4) or press enter

3. DRAWING OF POLYGON

Creates an equilateral closed polyline .A polygon is a polyline object. AUTOCAD draws polyline with zero width and no tangent information.

4. POINT

Creates a point object .points can act as nodes to which you can snap objects .you can specify a full 3D location for a point.

At the command prompt, enter point

Point: specify a point

5. ERASING OF OBJECT:

The object can be removed or erased by use of erase command ERASE
This removes object from drawing At the command prompt, enter erase
Select objects: use an object selection method.

6. COLOURING OF OBJECT:

The object can be drawn with any variety of colour: which ranges from 0 to 256. The setting of colour can be done by color command
COLOR

Sets the colour for new objects.

	CHH. SHAHU COLLEGE OF ENGINEERING, AURANGABAD		LABORATORY MANUAL
	PRACTICAL EXPERIMENT INSTRUCTION SHEET		
	EXPERIMENT TITLE -3-D model at least one simple machine component.		
DEPARTMENT:MECHANICAL ENGINEERING		LABORATORY: CSMSS/ENGG/MECH/CAD LAB	
LABORATORY MANUAL NO.: CSMSS/ENGG/MECH/MDCAD-04		YEAR:2024-25	
Class: Second Year	PART: I	SUBJECT: MDCAD	PAGE: 19 OF 36

At the command prompt, enter color <current>:enter a value (1-255),color name ,by block, or by layer

7. FILLING OF OBJECT: the object can be filled with different colors and patterns by use of hatch command

This command allows selection of various patterns, scale of pattern and angle of pattern.

HATCH

This fills an area with a pattern.

HATCH fills the specified hatch boundary with non-associative hatch

A non –associative hatch is not updated when its boundaries are modified .a hatch boundary consists of an object or objects that completely enclose an area

At the command prompt, enter hatch

Pattern (? Or name/ U, style) <current>: enter a predefined pattern name, enter u, enter? Or press enter.

8.SCALING OF DRAWING: zoom command displays the object at a specified scale factor. The value entered is relative to the limits of the drawing .for example, entering 2 doubles the apparent display size of any objects from what it would be if it were zoomed to the limits of the drawing. If you enter a value followed by xp, auto CAD specifies the scale relative to paper space units for example; entering 0.5xp displays model space at half the scale of paper space units. The following illustration shows a number of viewports arranged in paper space. the view in each view port is scaled relative to paper space .the first view is scaled 1=1 relative to paper space (1xp) ,the second is scaled 0.5=1 relative to paper space (0.5xp),and so on.

ZOOM

This increases or decreases the apparent size of objects in the current view port At the command prompt, enter zoom

	CHH. SHAHU COLLEGE OF ENGINEERING, AURANGABAD	LABORATORY MANUAL
	PRACTICAL EXPERIMENT INSTRUCTION SHEET EXPERIMENT TITLE -3-D model at least one simple machine component.	
DEPARTMENT:MECHANICAL ENGINEERING		LABORATORY: CSMSS/ENGG/MECH/CAD LAB
LABORATORY MANUAL NO.: CSMSS/ENGG/MECH/MDCAD-04		YEAR:2024-25
Class: Second Year	PART: I	SUBJECT: MDCAD
		PAGE: 20 OF 36

All/center/dynamic/extents/left/previous/vmax/window/<scale(x/xp)>:enter an option or value ,specify a point ,or press enter

1. **TEXT:** The text in software is indicated by font's .the fonts define the shapes of the text characters that make up each character set. In AUTOCAD, you can use true type fonts in addition to AUTOCAD's own compiled shape (SHX) fonts.

A font is indicated by various parameters like

- i. Style :these are four types: normal,bold,italic,underline
- ii. Size: this is the size of characters
- iii. Colour: there are facilities to colour the characters selecting layer.
- iv. Type: different types of fonts may be used:

Mono text: COMPUTER AIDED DESIGN Romans: COMPUTER AIDED DESIGN Romand:
COMPUTER AIDED DESIGN

Dtext: This displays text on the screen as it is entered .AutoCAD can create text with a variety of character patterns, or fonts. These fonts can be stretched, compressed, oblique, mirrored, or aligned in a vertical column by applying a style to the font .text can be rotated, justified, and made any size.

At the command prompt, enter **text**

Justify/style/<start point>: specify a point or enter an option

TEXT: This creates a single line of text .AutoCAD can create text with a variety of character patterns, or fonts. These fonts can be stretched, compressed, oblique, mirrored, or aligned in a vertical column by applying a style to the font.

At the command prompt, enter **text**

Justify/style/<start point>: specify a point or enter an option

QTEXT: This controls the display and plotting of text and attribute of objects. At the command

	CHH. SHAIHU COLLEGE OF ENGINEERING, AURANGABAD		LABORATORY MANUAL
	PRACTICAL EXPERIMENT INSTRUCTION SHEET		
	EXPERIMENT TITLE -3-D model at least one simple machine component.		
DEPARTMENT:MECHANICAL ENGINEERING		LABORATORY: CSMSS/ENGG/MECH/CAD LAB	
LABORATORY MANUAL NO.: CSMSS/ENGG/MECH/MDCAD-04		YEAR:2024-25	
Class: Second Year	PART: I	SUBJECT: MDCAD	PAGE: 21 OF 36

prompt, enter **text**

ON/OFF <current>: enter on or off, or press enter

3. **TRANSFORMATIONS:** These are the modifications in the drawn objects.

There are different types of transformations used

1. **MOVE:** This allows to move or displace objects a specified distance in a specified direction

At the command prompt, enter **move**

Select objects: use an object selection method

Base point or displacement: specify a base point (1)

Second point of displacement: specify a point (2) or press enter

2.**COPY:** This is used for producing a duplicate copy of the drawing.

At the command prompt, enter **copy**

Select objects: use an object selection method

<Base point or displacement >/multiple: specify

a base point(1)For a single copy or enter m for

multiple copies

3.**ROTATE:** It moves objects about a

	CHH. SHAHU COLLEGE OF ENGINEERING, AURANGABAD		LABORATORY MANUAL
	PRACTICAL EXPERIMENT INSTRUCTION SHEET		
	EXPERIMENT TITLE -3-D model at least one simple machine component.		
DEPARTMENT:MECHANICAL ENGINEERING		LABORATORY: CSMSS/ENGG/MECH/CAD LAB	
LABORATORY MANUAL NO.: CSMSS/ENGG/MECH/MDCAD-04		YEAR:2024-25	
Class: Second Year	PART: I	SUBJECT: MDCAD	PAGE: 22 OF 36

base pointAt the command prompt,

enter **rotate**

Select objects: use an object selection method

<Rotate angle >/reference: specify an angle or enter r

4.STRETCH: This moves or stretches objects .AutoCAD stretches lines, arcs, ellipticalarcs, splines, rays and polyline segments that cross the selection window.

At the command prompt, enter **stretch**

Select objects: use the CPOLYGON or cross object

selection method(1,2)Base point or displacement: specify

a point (3) or press

Second point of displacement: specify a point (\$) or press

5. EXTEND: This extends an object to meet another object. Objects that

6. can be extended include arcs, elliptical arcs, lines, open 2D, and 3Dpolylines and rays.At command prompt, enter extend

	CHH. SHAHU COLLEGE OF ENGINEERING, AURANGABAD		LABORATORY MANUAL
	PRACTICAL EXPERIMENT INSTRUCTION SHEET		
	EXPERIMENT TITLE -3-D model at least one simple machine component.		
DEPARTMENT:MECHANICAL ENGINEERING		LABORATORY: CSMSS/ENGG/MECH/CAD LAB	
LABORATORY MANUAL NO.: CSMSS/ENGG/MECH/MDCAD-04		YEAR:2024-25	
Class: Second Year	PART: I	SUBJECT: MDCAD	PAGE: 23 OF 36

Select boundary edges

(projmode=UCS, edge mode=no extend) Select objects: use an object selection method

7. SCALE: This enlarges or reduces selected objects equally in X and Y directions At the command prompt, enter scale

Select objects: use an object selection method Base point: specify a point (1)
<Scale factor>/reference: specify a scale or enter r

8. TRACE: This creates solid lines.

From the miscellaneous tool bar choose At the command prompt, enter trace

Trace width<current>: specify a distance, enter a value ,or press enter From point: specify point (1)

To point: specify a point (2)

To point: specify a point (3) or press to end the command

9. EXTRUDE: This creates unique solid primitives by extruding existing two- dimensional objects extrudes also creates solids by extruding two- dimensiona

	CHH. SHAHU COLLEGE OF ENGINEERING, AURANGABAD		LABORATORY MANUAL
	PRACTICAL EXPERIMENT INSTRUCTION SHEET		
	EXPERIMENT TITLE -3-D model at least one simple machine component.		
DEPARTMENT:MECHANICAL ENGINEERING		LABORATORY: CSMSS/ENGG/MECH/CAD LAB	
LABORATORY MANUAL NO.: CSMSS/ENGG/MECH/MDCAD-04		YEAR:2024-25	
Class: Second Year	PART: I	SUBJECT: MDCAD	PAGE: 24 OF 36

objects along a specified path .we can extrude multiple objects with extrude

At the command prompt enter, extrude

Select objects: use an object selection method

Path/<height of extrusion>: specify a distance or enter p

11. **MIRROR:** This is used to producing mirror image of the object

At the command prompt enter, mirror

Select objects: use an object selection method First point of the mirror line: specify a point (1)

Second point: specify a point (2)

12. **OFFSET:** This creates concentric circles ,parallel lines and parallel curves, offset creates a creates a new object at a specified distance from an existing object or through a specified point

At the command prompt enter, offset

Offset distance: specify a distance, enter t or press enter

13. **ARRAY:** This creates multiple copies of objects in pattern. Arrays are three types.

a) Rectangular Array

b) Path Array

c) Polar Array

Rectangular Array: In this, the object is arranged in an array of rows and columns

	CHH. SHAHU COLLEGE OF ENGINEERING, AURANGABAD		LABORATORY MANUAL
	PRACTICAL EXPERIMENT INSTRUCTION SHEET		
	EXPERIMENT TITLE -3-D model at least one simple machine component.		
DEPARTMENT:MECHANICAL ENGINEERING		LABORATORY: CSMSS/ENGG/MECH/CAD LAB	
LABORATORY MANUAL NO.: CSMSS/ENGG/MECH/MDCAD-04		YEAR:2024-25	
Class: Second Year	PART: I	SUBJECT: MDCAD	PAGE: 25 OF 36

Rectangular Array: In this, the object is arranged in an array of rows and columns.

At the command prompt: type **ARRAYRECT** or select the option from **MODIFY** toolbar. It asks you to select objects. Select the object and press enter. By default, it shows an array of 3 rows and 4 columns. The no. of rows and columns can be changed by selecting the **COUNt** option (OR) by selecting COLUMNS and ROWS options separately

Path Array: In this, an object is arranged in a specified path.

At the command prompt: type **ARRAYPATH** or select the option from **MODIFY** toolbar. Then select object to be arrayed. Then select the path through which the object is made to be arrayed.

2. CUTTING OF OBJECTS

The drawn objects can be cut or trimmed by using following commands

1. **TRIM:** Trims objects at a cutting object defined by other objects. Objects that can be trimmed include arcs, circles, elliptical arcs, lines, open 2D and 3D polylines, rays and splines

At the command prompt, enter **trim**

Select cutting edges:

Select objects: use object selection method

	CHH. SHAHU COLLEGE OF ENGINEERING, AURANGABAD		LABORATORY MANUAL
	PRACTICAL EXPERIMENT INSTRUCTION SHEET		
	EXPERIMENT TITLE -3-D model at least one simple machine component.		
DEPARTMENT:MECHANICAL ENGINEERING		LABORATORY: CSMSS/ENGG/MECH/CAD LAB	
LABORATORY MANUAL NO.: CSMSS/ENGG/MECH/MDCAD-04		YEAR:2024-25	
Class: Second Year	PART: I	SUBJECT: MDCAD	PAGE: 26 OF 36

<Select object to trim>/project/edge/undo: select an object, enter an option, or press enter

2. **BREAK:** This erases an object or splits the object in to two parts From the modify toolbar select break flyout At the command prompt, enter **break**

Select objects: use an object selection method

First point of the mirror line: specify a point (1)
on an object Enter second point: specify the
second break point (2) or enter F

13. DIMENSIONING IN DRAWINGS:

The dimensions are inserted in the drawing by use of DIM command. There are various types of dimensions used in AutoCAD.

1. Linear dimensions:

Horizontal- this allows
horizontal dimensions Vertical-
this allows vertical dimensions
Aligned- this allows inclined
dimensions Rotated- this
allows inclined dimensions

2. Angular dimensions:

	CHH. SHAHU COLLEGE OF ENGINEERING, AURANGABAD		LABORATORY MANUAL
	PRACTICAL EXPERIMENT INSTRUCTION SHEET		
	EXPERIMENT TITLE -3-D model at least one simple machine component.		
DEPARTMENT:MECHANICAL ENGINEERING		LABORATORY: CSMSS/ENGG/MECH/CAD LAB	
LABORATORY MANUAL NO.: CSMSS/ENGG/MECH/MDCAD-04		YEAR:2024-25	
Class: Second Year	PART: I	SUBJECT: MDCAD	PAGE: 27 OF 36

This allows angular dimensioning of objects

3. Radial dimensions:

This allows radial dimensioning of arc or circle

4. Diametric dimensions:

This allows diametral dimensions of the circle

For dimensioning of objects, the first point and second point has to be specified. The dimension text must be written and then the position of dimension must be specified

at the command prompt ,enter **dim**

Dim: Enter a dimensioning mode command

14. AREA:

This allows calculation of the area and perimeter of objects or of defined areas From the object properties toolbar, choose the inquiry flyout, then

At the command prompt, enter **area**

<First point>/object/add/subtract: specify a point or enter option

15. FILLET

Rounds and fillets the

	CHH. SHAHU COLLEGE OF ENGINEERING, AURANGABAD		LABORATORY MANUAL
	PRACTICAL EXPERIMENT INSTRUCTION SHEET		
	EXPERIMENT TITLE -3-D model at least one simple machine component.		
DEPARTMENT:MECHANICAL ENGINEERING		LABORATORY: CSMSS/ENGG/MECH/CAD LAB	
LABORATORY MANUAL NO.: CSMSS/ENGG/MECH/MDCAD-04		YEAR:2024-25	
Class: Second Year	PART: I	SUBJECT: MDCAD	PAGE: 28 OF 36

edges of the objectAt the
command prompt enter

fillet

Polyline / Radius / Trim / <Select first object>: use an object selection
method or enter aoption

Select first object

Select second object: use an object selection method

Enter radius <current>: specify a distance or press

Chain / Radius <Select edge>: Select edges or enter **c** or **r** their intersection

16. CO-ORDINATE SYSTEM

The co- ordinate system can be modified in the AutoCAD. There are two
types of co- ordinate systems used. The WCS (World co- ordinate system)
is a universal system in which its origin is at the fixed position. The UCS
(User co- ordinate system) is a system in which user can fix his origin at
any point.

1. UCS : This manages user co-
ordinate systemsAt the command

prompt enter **ucs**

Origin / z axis/ 3 point/ object/ view/ X/Y/Z / Prev/ Restore/Save/ Del/?/<
world>: enter aoption or press enter

	CHH. SHAHU COLLEGE OF ENGINEERING, AURANGABAD		LABORATORY MANUAL
	PRACTICAL EXPERIMENT INSTRUCTION SHEET		
	EXPERIMENT TITLE -3-D model at least one simple machine component.		
DEPARTMENT:MECHANICAL ENGINEERING		LABORATORY: CSMSS/ENGG/MECH/CAD LAB	
LABORATORY MANUAL NO.: CSMSS/ENGG/MECH/MDCAD-04		YEAR:2024-25	
Class: Second Year	PART: I	SUBJECT: MDCAD	PAGE: 29 OF 36

2. WCS: This manages world co-ordinate system

17. **EXPLODE:**

This breaks a compound object into its

component objects. At the command prompt

enter **explode**

Select objects: use an object selection method.

18. **UNION:**

This measures the distance and angle

between two points. At the command

prompt, enter **union**

Select object: Use an object selection method

DIST: This measures the distance and the angle between two points

At the command prompt area enter **dist**

First point : Specify a point (1)

	CHH. SHAHU COLLEGE OF ENGINEERING, AURANGABAD		LABORATORY MANUAL
	PRACTICAL EXPERIMENT INSTRUCTION SHEET		
	EXPERIMENT TITLE -3-D model at least one simple machine component.		
DEPARTMENT:MECHANICAL ENGINEERING		LABORATORY: CSMSS/ENGG/MECH/CAD LAB	
LABORATORY MANUAL NO.: CSMSS/ENGG/MECH/MDCAD-04		YEAR:2024-25	
Class: Second Year	PART: I	SUBJECT: MDCAD	PAGE: 30 OF 36

Second point :
Specify a point (2)
Distance =
calculated distance
Angle in XY plane = angle from XY plane = angle

Delta X =
change in
X Delta Y
= change
in Y Delta
Z = change
in Z.

19. REGENERATION OF DRAWING:

ACAD provides a facility of regenerating a drawing to clear the cross points or marks on the screen.

- REDRAW
- REGEN
- REGENALL
- REGENAUTO

20. TOLERANCE

This creates geometric tolerances. Geometric tolerances define the maximum allowable variations of form or profile, orientation, location

	CHH. SHAHU COLLEGE OF ENGINEERING, AURANGABAD		LABORATORY MANUAL
	PRACTICAL EXPERIMENT INSTRUCTION SHEET		
	EXPERIMENT TITLE -3-D model at least one simple machine component.		
DEPARTMENT:MECHANICAL ENGINEERING		LABORATORY: CSMSS/ENGG/MECH/CAD LAB	
LABORATORY MANUAL NO.: CSMSS/ENGG/MECH/MDCAD-04		YEAR:2024-25	
Class: Second Year	PART: I	SUBJECT: MDCAD	PAGE: 31 OF 36

and run out from the exact geometry in a drawing. They specify the required accuracy for proper function and fit the objects drawn in AutoCAD

21. SKETCH

This creates a series of free hand line segments. From the miscellaneous toolbar, choose
At the command prompt enter **sketch**

Follow the prompting

2.3 3D FUNCTIONS

1. BOX

This creates a three dimensional solid box. At the command prompt enter **box**

Center/ <corner of the

box><0,0,0> :

Specify a point (1), enter c,

or press enter Corner of a

	CHH. SHAHU COLLEGE OF ENGINEERING, AURANGABAD		LABORATORY MANUAL
	PRACTICAL EXPERIMENT INSTRUCTION SHEET		
	EXPERIMENT TITLE -3-D model at least one simple machine component.		
DEPARTMENT:MECHANICAL ENGINEERING		LABORATORY: CSMSS/ENGG/MECH/CAD LAB	
LABORATORY MANUAL NO.: CSMSS/ENGG/MECH/MDCAD-04		YEAR:2024-25	
Class: Second Year	PART: I	SUBJECT: MDCAD	PAGE: 32 OF 36

box

Specifying a point or pressing defines the first corner of

the box. Cube/length /<other corner>: specify a point (2)

or enter an option **center**Creates the box by a specified

center point

2. CONE

This creates a 3D solid cone. A cone is solid primitive with a circular or elliptical based tapering symmetrically to a point perpendicular to its base.

At the command prompt enter **cone**

Elliptical /<center point> <0,0,0> : specify a point , enter e or press enter

3. CYLINDER

This creates a 3D solid cylinder. A cylinder is solid primitive with a circular or elliptical based to a point perpendicular to its base without a taper.

At the command prompt enter **cylinder**

Elliptical /<center point> <0,0,0> : specify a point , enter e or press enter

SPHERE

	CHH. SHAHU COLLEGE OF ENGINEERING, AURANGABAD		LABORATORY MANUAL
	PRACTICAL EXPERIMENT INSTRUCTION SHEET		
	EXPERIMENT TITLE -3-D model at least one simple machine component.		
DEPARTMENT:MECHANICAL ENGINEERING		LABORATORY: CSMSS/ENGG/MECH/CAD LAB	
LABORATORY MANUAL NO.: CSMSS/ENGG/MECH/MDCAD-04		YEAR:2024-25	
Class: Second Year	PART: I	SUBJECT: MDCAD	PAGE: 33 OF 36

This creates a 3D solid sphere. A sphere is positioned so that its central axis is parallel to the Z-axis of the current UCS. Latitudinal lines are parallel to the XY plane.

At the command prompt enter **sphere**

Center of the sphere <0,0,0> : specify a point , enter e or press enter

4. WEDGE

This creates a three dimensional solid with a sloped face tapering along X axis. At the command prompt enter **wedge**
Center <corner of the wedge> <0,0,0> : specify a point , enter e or press enter
Follow the prompting

5. ELEV

This sets an elevation and extrusion thickness of new objects. The current elevation is the Z value that is used whenever a 3D point is expected but only X and y values are supplied.

At the command prompt enter **elev**

Follow the prompting

6. SHADE

This displays a flat shaded image of the drawing in the current view port. SHADE removes hidden lines and displays a shaded picture of the drawing.

	CHH. SHAHU COLLEGE OF ENGINEERING, AURANGABAD		LABORATORY MANUAL
	PRACTICAL EXPERIMENT INSTRUCTION SHEET		
	EXPERIMENT TITLE -3-D model at least one simple machine component.		
DEPARTMENT:MECHANICAL ENGINEERING		LABORATORY: CSMSS/ENGG/MECH/CAD LAB	
LABORATORY MANUAL NO.: CSMSS/ENGG/MECH/MDCAD-04		YEAR:2024-25	
Class: Second Year	PART: I	SUBJECT: MDCAD	PAGE: 34 OF 36

From the render toolbar, choose

At the command prompt, enter **shade**

7. REGION

This creates a region object from a selection set of existing objects. Regions are 2-Dimensional areas you create from closed shapes.

8. REINIT

This reinitializes the input/output ports, digitizer, display and program parameters. The

9. REPLAY

This displays a GIF, TGA or

TIFF image. From the tools

menu, choose image, then view.

10. REVOLVE

This creates a solid by revolving a two – dimensional object about an axis.

From the solidstoolbar, choose

At the command prompt, enter **revolve**

	CHH. SHAHU COLLEGE OF ENGINEERING, AURANGABAD		LABORATORY MANUAL
	PRACTICAL EXPERIMENT INSTRUCTION SHEET		
	EXPERIMENT TITLE -3-D model at least one simple machine component.		
DEPARTMENT:MECHANICAL ENGINEERING		LABORATORY: CSMSS/ENGG/MECH/CAD LAB	
LABORATORY MANUAL NO.: CSMSS/ENGG/MECH/MDCAD-04		YEAR:2024-25	
Class: Second Year	PART: I	SUBJECT: MDCAD	PAGE: 35 OF 36

11. SHAPE

This inserts a shape. Before inserting a shape, you must load the file containing the desired shape.

12. ROTATE 3D

This moves objects about a three dimensional axis From the modify toolbar, choose the rotate flyout then

Follow the prompting

13. SECTION

This uses the intersection of a plane and solids to create a region.

AutoCAD creates regions on the current layer and inserts them at the location of the cross –section. Selecting several solids creates separate regions for each solid.

14. SLICE

This slices a set of solids with a plane.

15. SHELL

	CHH. SHAHU COLLEGE OF ENGINEERING, AURANGABAD		LABORATORY MANUAL
	PRACTICAL EXPERIMENT INSTRUCTION SHEET		
	EXPERIMENT TITLE -3-D model at least one simple machine component.		
DEPARTMENT:MECHANICAL ENGINEERING		LABORATORY: CSMSS/ENGG/MECH/CAD LAB	
LABORATORY MANUAL NO.: CSMSS/ENGG/MECH/MDCAD-04		YEAR:2024-25	
Class: Second Year	PART: I	SUBJECT: MDCAD	PAGE: 36 OF 36

This accesses operating system commands.

16. REVOLVE

This creates a solid by revolving a two dimensional object about an axis.

17. RENDER

This creates a realistically shaded image of a three dimensional wireframe or solid model. RENDER produces an image using information from a scene, the current selection set, or the current view.

2.4 Starting the drawing

The figures we do in engineering are fitted into a template. In ACAD we manually draw a template known as *Drawing sheet* in two different formats.

The size of the drawing sheet is ISO A4 210 X 297. The format is as given in the following figures

Polar Array: In this, an object is arranged in a circular shape.

At the command prompt: type **ARRAYPOLAR** or select the option from **MODIFY** toolbar. Then select object to be arrayed. Then select the center point of array. By default, a six items array is created. The No. of items can be changed by selecting the **Items** option. Angle between the two items can also be changed.

CHH.SHAHU COLLEGE OF ENGINEERING
DEPARTMENT OF MECHANICAL ENGINEERING

3. 2D DRAWINGS

FIGURE 1

Aim: to draw the following figure using ACAD

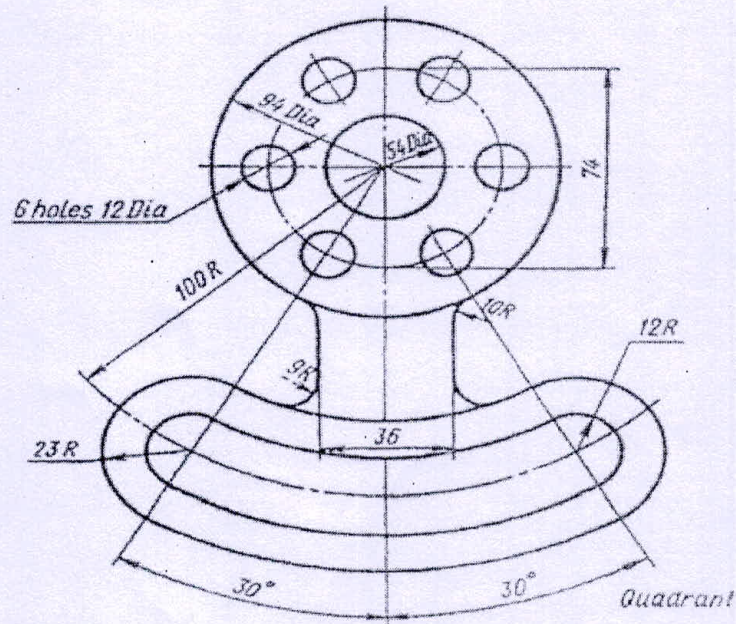

PROCEDURE

Set the limits of the drawing screen

STEP 1: Draw axis lines in the respective format with their intersection point at (0,0)

- Go to **PROPERTIES** tool bar
- Load line type as **ISO LONG DASH SHORT DASH** in the line type area.
- Select line type ISO LONG DASH SHORT DASH in the line type area.

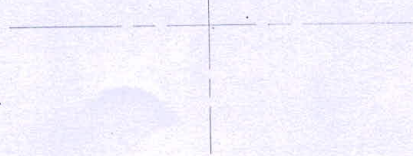

STEP 2 a: Draw circles of given dimensions using circle command with their



CHH.SHAHU COLLEGE OF ENGINEERING
DEPARTMENT OF MECHANICAL ENGINEERING

PRACTICE FIGURE 3

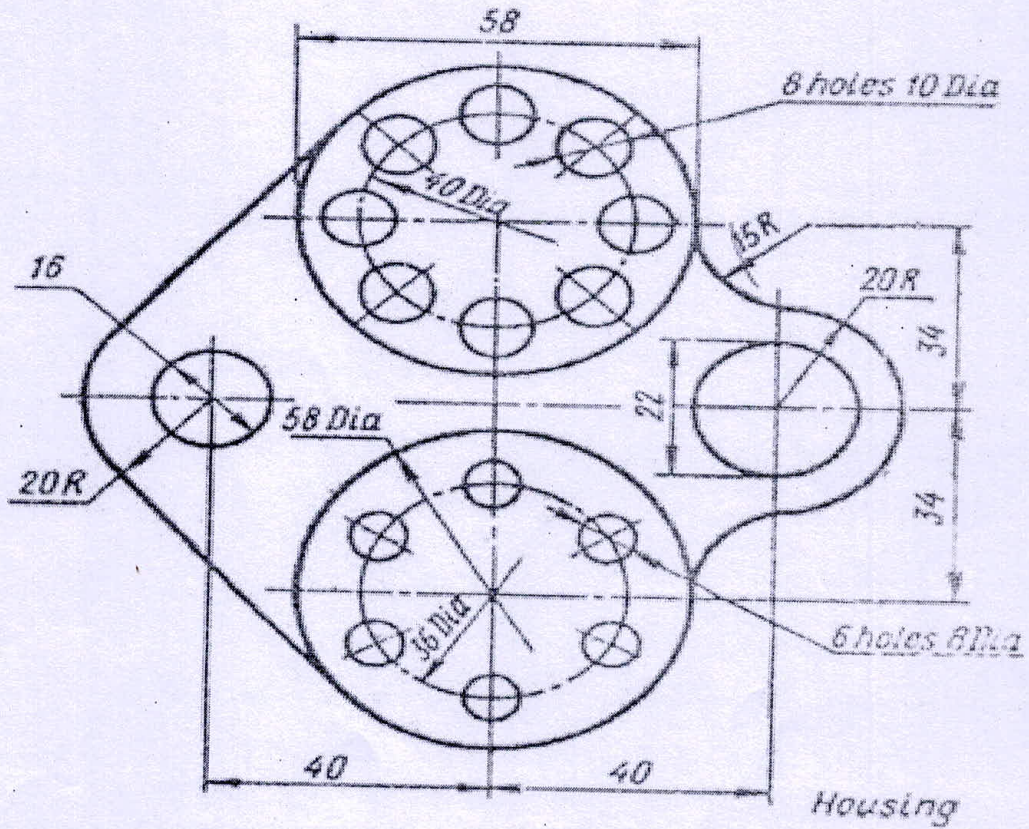



CHH.SHAHU COLLEGE OF ENGINEERING
DEPARTMENT OF MECHANICAL ENGINEERING

4. ISOMETRIC DRAWINGS

For all isometric figures right click **GRID** in drafting tool bar <setting> change grid snap to **ISOMETRIC SNAP**. And check **ORTHO ON**
F5 – TOGGLE KEY BETWEEN ISOPLANE TOP, ISOPLANE LEFT AND ISOPLANE RIGHT

FIGURE 1

Aim: to draw the following figure using ACAD

COMMANDS USED

Line, Dimensions, Drafting commands

PROCEDURE

<Ortho on> <Isoplane Top> <Osnap on>

Command: _line Specify first point:

Specify next point or [Undo]: 104

Specify next point or [Undo]:

Command: _qsave

Command:

_dimaligned

Specify first extension line origin or

<select object>:

Specify second extension line origin:

Command: _dimlinear

Specify first extension line origin or <select object>:

Specify second extension line origin:

Specify dimension line location or

[Mtext/Text/Angle/Horizontal/Vertical/Rotated]:Dimension text = 48.0000

Command: _dimedit

Enter type of dimension editing [Home/New/Rotate/Oblique] <Home>: **_o**

Select objects: 1 found

Enter obliquing angle (press ENTER for none): **30**

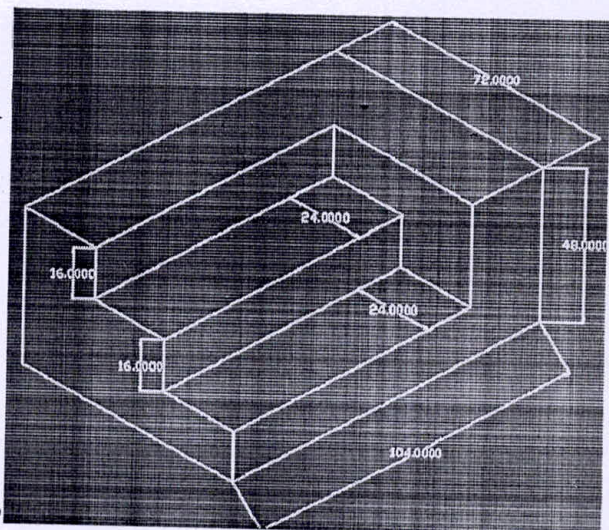



FIGURE 2

Aim: to draw the following figure using ACAD

COMMANDS USED

Line, Drafting commands, Dimension aligned, Dimension linear, Dimension oblique, Layers

Command: _line

Specify first point: <Isoplane

Left>Specify next point or

[Undo]: 12 Specify next point or

[Undo]:

<Isoplane Top> 25

Command: _qsave

Command:

_dimlinear

Specify first extension line

origin or <select object>:

Specify second extension line

origin:

Specify dimension line location or

[Mtext/Text/Angle/Horizontal/Vertical/Rotated]:

Dimension text = 12.0000

Command: _dimaligned

Specify first extension line origin or <select

object>:Specify second extension line origin:

Specify dimension line location or

[Mtext/Text/Angle]:Dimension text = 25.0000

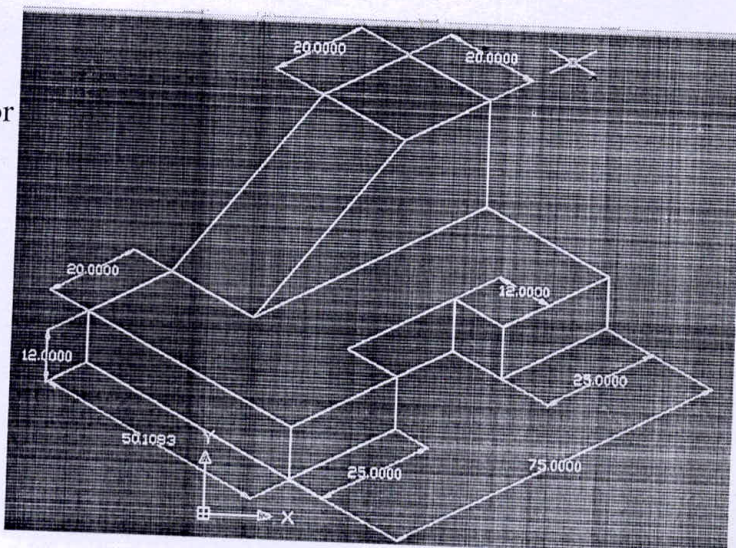



CHH.SHAHU COLLEGE OF ENGINEERING
DEPARTMENT OF MECHANICAL ENGINEERING

EXPERIMENTNO-04(a): 3-D model at least one simple machine component.

