



CSMSS

CHH. SHAHU COLLEGE OF ENGINEERING

Kanchanwadi, Paithan Road, Chhatrapati Sambhajnagar-

431002



DEPARTMENT OF
MECHANICAL ENGINEERING
MATERIAL SCIENCE & METALLURGY LAB
MANUAL

Prepared By:

Prof.D.P.Narmala

List of Experiments:

- 1. Brinell hardness Test.**
- 2. Rockwell Hardness test.**
- 3. Study and drawing of microstructures of plain carbon steels of varying carbon percentage.**
- 4. Study and drawing of microstructures of heat treated steels.**
- 5. Study and drawing of microstructures of cast irons.**
- 6. Study and drawing of microstructures of non-ferrous alloys**

DO's

1. Students must always wear uniform and shoes before entering the lab.
2. Proper code of conduct and ethics must be followed in the lab.
3. Windows & doors to be kept open for proper ventilation and air circulation.
4. Note down the specifications of the experimental setup before performing the experiment.
5. Check for the electrical connections and inform if any discrepancy found to the attention of lecturer/lab instructor.
6. Perform the experiment under the supervision/guidance of a lecturer/lab instructor only.
7. After the observations are noted down switch off the electrical connections.
8. In case of fire use fire extinguisher/throw the sand provided in the lab.
9. In case of any physical injuries or emergencies use first aid box provided.
10. Any unsafe conditions prevailing in the lab can be brought to the notice of the lab in charge.

DONT's

1. Do not operate any experimental setup to its maximum value.
2. Do not touch/ handle the experimental setups/Test Rigs without their prior knowledge,
3. Never overcrowd the experimental setup/Test Rig, Leave sufficient space for the person to operate the equipment's.
4. Never rest your hands on the equipment or on the display board, because it has fragile measurement devices

EXPERIMENT No. 01

BRINELL HARDNESS TEST

AIM: To determine the hardness of the given specimen using Brinell hardness test.

APPARATUS: Brinell hardness testing machine, Aluminum specimen, Ball indenter.

DIAGRAM:

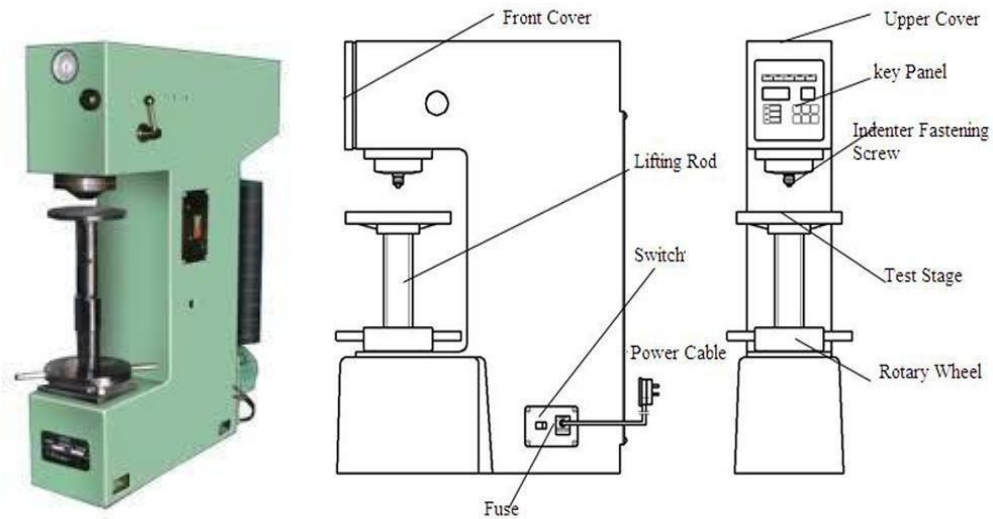

THEORY:

In Brinell hardness test, a steel ball of diameter (D) is forced under a load (F) on to a surface of test specimen. Mean diameter (d) of indentation is measured after the removal of the load (F).

Its specifications as follows:

1. Ability to determine hardness up to 500BHN.
2. Diameter of ball (as indenter) used $D= 2.5\text{mm}, 5\text{mm}, 10\text{mm}$.
3. Maximum application load= 3000kgf
4. Method of load application= Lever type
5. Capability of testing the lower hardness range= 1BHN on application of $0.5D^2$ load.

PROCEDURE:

1. Insert ball of diameter ' D ' in the ball holder of machine.
2. Make the specimen surface clean by oil, grease, dust etc.
3. Make contact between the specimen surface and ball using jack adjusting wheel.
4. Push the required button for loading.

5. Pull the load release level and wait for 15 seconds.
6. Remove the specimen from the support table and locate the Indentation.
7. View the indentation through microscope and measure the diameter 'd' of the indentation using micrometer fixed on the microscope.
8. Repeat the procedure and take three readings.

OBSERVATIONS:

Test piece material =

Diameter of the ball D =

Load section F/D^2 =

Test load =

Load application time =

Least count of Brinell Microscope =

S.NO	Ball Diameter D in mm	Load applied F in kgf	Diameter of indentation	$\frac{P}{D^2}$	

$$\text{BHN} = \frac{\text{Load Applied (kgf)}}{\text{spherical surface area of indentation}}$$

$$\text{BHN} = \frac{2P}{\pi D(D - \sqrt{D^2 - d^2})}$$

PRECAUTION:

1. Make sure that beam and load placed a proper position.
2. The cross- section of the beam should be large.
3. Note down the readings more carefully..

VIVA QUESTIONS:

1. How to measure the hardness
2. What are the formulae of BHN?
3. Which ball size is recommended for Brinell test?
4. What is the difference between the brinell and Rockwell hardness test?
5. For steel ultimate tensile strength = ----- BHN?

APPLICATIONS:

1. In manufacturing Industries



2. Bearing Manufacturing industries



EXPERIMENT No.02

ROCKWELL HARDNESS TESTER

AIM: To determine the hardness of the given Specimen using Rockwell hardness test.

APPARATUS: Rockwell hardness testing machine,

MATERIAL: soft and hard mild steel specimens, brass, Aluminum etc., Black diamond cone indenter.

DIAGRAM:

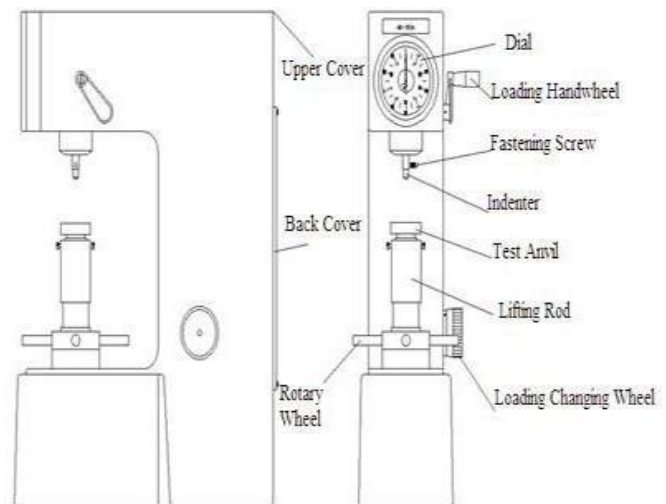

THEORY:

Rockwell test is developed by the Wilson instrument co U.S.A in 1920. This test is an indentation test used for smaller specimens and harder materials. The test is subject of IS: 1586. The hardness of a material is resistance to penetration under a localized pressure or resistance to abrasion. Hardness tests provide an accurate, rapid and economical way of determining the resistance of materials to deformation.

There are three general types of hardness measurements depending upon the manner in which the test is conducted:

- a. Scratch hardness measurement,
- b. Rebound hardness measurement
- c. Indention hardness measurement.

In scratch hardness method the material are rated on their ability to scratch one another and it is usually used by mineralogists only. In rebound hardness measurement, a standard body is usually dropped on to the material surface and the hardness is measured in terms of the height of its rebound .The general means of judging the hardness is measuring the resistance of a material to indentation. The indenters usually a ball cone or pyramid of a material much harder than that being used. Hardened steel, sintered tungsten carbide or diamond indenters are generally used in

PROCEDURE:

1. Examine hardness testing machine (fig.1)
2. Place the specimen on platform of a machine. Using the elevating screw raise the platform and bring the specimen just in contact with the ball. Apply an initial load until the small pointer shows red mark.
3. Release the operating valve to apply additional load. Immediately after the additional load applied, bring back operating valve to its position.
4. Read the position of the pointer on the C scale, which gives the hardness number.
5. Repeat the procedure five times on the specimen selecting different points for indentation.

OBSERVATION TABLE:

S.NO	Specimens	Reading (HRC/)			Mean	
		1	2	3		
1	Mild Steel				HRB =	
2	Aluminum				HRB =	

PRECAUTIONS:

1. The specimen should be clean properly
2. Take reading more carefully and
3. The test should not be made on specimens so thin that the impression shows through the metal, nor should impression be made too close to the edge of a specimen.

VIVA QUESTIONS:

1. Define Hardness
2. Size of the Ball to be used in Ball Indenter of Rockwell Hardness Test.
3. Different Types of Hardness Testing Methods.
4. Applications of Rockwell Hardness A – Scale, B-Scale, C-Scale
5. In Rockwell hardness test the hardness is measured by?

APPLICATIONS:

1. In manufacturing Industries



2. Bearing Manufacturing industries



EXPERIMENT No. 03

To the study of Microstructure of Low, Medium & High carbon steels.

1. AIM: To identify the different phases and to draw the microstructures of Plain Carbon Steels.

2. APPARATUS AND SPECIMENS:

Metallurgical Microscope, specimens of Plain carbon steel of different composition (untreated)

3. THEORY

Alloy:

Combination of two or more metals is called alloy. The substances that make the alloy are called its components. The metals are mixed together in required proportion when they are in molten form and then they are allowed to solidify together. After solidification the components of alloy may be in the form of solid solution, chemical compound, and mechanical mixture.

If the constituents of the alloy are completely soluble in both liquid and solid state a solid solution is formed. If constituents of the alloy are completely soluble in liquid state and completely insoluble in solid state a mechanical mixture is formed.

Phases

A homogeneous, physically distinct and mechanically separable part of the system under study is known as phase.

Cooling Curve:

For a molten metal that is cooled from state to room temperature the graph drawn between time on x-axis and temperature on Y-axis is known as cooling curve. A pure metal solidifies at constant temperature.

3.2 a. Cooling Curve of Pure metal:

Cooling Curve of pure metal is shown in fig.2.1. At 'A' metal is in liquid state. As metal is cooled the solidification starts at "B". As metal is further cooled the temperature of metal remains constant but metal is converted from liquid state to solid state. Solidification is completed at point 'C'. From 'C' to 'D' there is no change in the solidified metal (except fall in temperature).

3.2 b. Cooling curve of a solid solution:

If the components of the alloy are completely soluble in both liquid and solid state a solid solution is formed. Cooling curve of solid solution is shown in fig 'A' to 'B' the alloy is in liquid state. Solidification starts at 'B' and solidification ends at 'C'. From 'C' to 'D' there is no change in solid state of alloy. From 3.2 it can be observed that a solid solution alloy is solidified over a range of temperature.

c. Cooling curve of an eutectic alloy:

Cooling curve of a binary eutectic alloy is shown in fig.2.3. From 'A' to 'B' the alloy is in liquid state. As alloy is further cooled from 'B' the temperature of alloy remains constant, and two solids S₁, S₂ start separating out from the liquid separately. The alloy gets completely

solidified at 'C' and gives a mixture of S1 and S2 (eutectic mixture). From 'C' to 'D' there is no change in the solidified alloy.

Cooling curve of pure Iron

Cooling curve of pure Iron is shown in fig.2.4 Depending on the temperature Iron exists in separate crystalline forms (α , γ , and δ). Above 1539°C Iron is further cooled to 1400°C Iron is in the form of δ – Iron and at 1400°C ALL δ -Iron is converted to γ -Iron. As the iron is still cooled from 1400°C to 910°C Iron is in the form of γ -Iron and at 910°C all γ –Iron is converted to nonmagnetic α -Iron. If the further cooled from 910 at 768°C non magnetic α – Iron is converted to Magnetic α –Iron. If the Iron is further cooled to room temperature Iron exists as magnetic α - Iron only.

4Iron-Iron Carbide equilibrium diagram:

Iron-Iron Carbide equilibrium diagram is shown in fig.2.5

Iron carbon alloys contain less than 2% carbon are called steels and Iron carbon alloy that contains $>2\%$ Carbon alloys cast irons. Steels having $<0.8\%$ Carbon, 0.8% carbon and $>0.8\%$ carbon are called Hypo eutectoid steels, eutectoid steels and Hyper eutectoid steels respectively.

Curie temperature (768°C):

At curie temperature on cooling Non- magnetic α -iron becomes magnetic.

ABCD is the liquids line and AHJECF the solidus line of the system.(i.e. the alloy will be completely in liquid state at all temperatures above liquids line and will be under solid state at all temperatures below solidus line).

Critical points:

The temperature at which the transformation in solid state occurs are called critical points. In hypo eutectoid steels GS (A3 line) represents upper and lower critical points. In hyper eutectoid steels the line SE(Acm) and SK(A13) and SK(A13) represents upper and lower critical temperatures respectively.

Different phases that appear in Fe-Fe₃C diagram:

- a. Ferrite(α): It is an interstitial solid solution of carbon in α -iron, maximum solubility of carbon in α -iron is 0.025% at 723°C
 - b. Austenite (γ): It is an interstitial solid solution of carbon in γ -iron, maximum solubility of carbon in γ -iron is 0.2% at 1130°C
 - c. Cementite(Fe_3C): It is a chemical compound of Iron and carbon that contains 6.67% carbon by weight.
 - d. Pearlite: The eutectoid mixture of Ferrite and cementite is called Pearlite.
 - e. Ledeburite: The eutectic mixture of austenite and cementite is called Ledeburite
- the three horizontal lines in the diagram (HJB, ECF and PSK) indicate three isothermal reactions at fixed composition and temperature.

Slow Cooling of Hypo Eutectoid steel(0.18% Carbon):

In fig 2.5 alloy 1 represents 0.18% carbon steel. Initially at X, the alloy is in completely liquid

state as shown in fig 3.0a. As it is cooled when it crosses 'AB' line δ -iron nuclei start forming in liquid Iron. The Micro structure of the alloy at X2 is shown in fig 2.6b. as alloy is further cooled When it crosses' BJ line at J liquid Iron and δ -Iron are combined together at constant temperature to form δ -iron. This reaction is known as peritectic reaction.

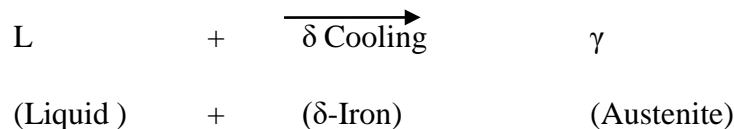

If the alloy is further cooled at X3 the microstructure of the alloy consists of homogeneous solid solution of γ Iron as shown in fig.2.6c.

Upon slow cooling of alloy from X3 nothing happens until 'A3' line is crossed. As alloy is cooled below' A3' line ferrite begins to form at austenite grain boundaries. The micro structure of alloy at X4 is shown if fig. 2.6d. As cooling progresses amount of ferrite increases and remaining and remaining austenite becomes richer in Carbon

On further cooling of alloy from X4 it crosses A1 line(lower critical temperature line)at X6. The microstructure of alloy 1 at X5(just above A1 line) is shown in fig 2.6e. the microstructure shows austenite (around 22%) and proeutectoid ferrite (77%).

At X6 the Austenite gets converted into ferrite and cementite(a Mechanical mixture) at constant temperature. This is known as eutectoid reaction.



The eutectoid mixture of ferrite and cementite is known as pearlite. At temperature just below X6 the micro structure shows pearlite and proeutectoid ferrite as shown in fig.2.6f.

On further cooling of the alloy to room temperature no more phase changes are observed. Hence at room temperature micro structure shows pearlite and proeutectoid ferrite.

Cooling of Eutectoid steel(0.8% Carbon):

In fig 2.5 alloy 2 represents 0.8% Carbon steel. Initially at X1 the alloy is completely in liquid state as shown on in fig.2.7a. On slow cooling once it crosses 'BC' line (liquids line) - γ -iron dendrites start forming in the liquid Iron. At X2 alloy consists of uniform solid solution of γ -iron as shown in fig.2.7c. On further cooling cooling of alloy from X3 no change is observed unit it crosses 'PSK' line (lower critical temperature (7230C) and gets converted into pearlite (mechanical mixture of ferrite and cementite).

Just below the eutectoid temperature ('PSK') at X4 the alloy consists of 100% pearlite as shown in fig. 2.7d. There is no change in microstructure on cooling of the alloy from X4, to room temperature.

Cooling of Hyper eutectoid steel (1% Carbon):

In fig 2.5 alloy 3 represents 1% carbon steel, initially at X1 the alloy is completely in liquid state as shown in fig.2.8a. on a slow cooling from observed till 'BC' line (liquid line) is crossed. Once 'BC' line is crossed on further cooling of alloy to X2 austenite crystals start nucleating from liquid iron as shown in fig.2.8b. as cooling is continued more and more amount of austenite is formed. By the time it crosses the line 'JE' all liquid iron is converted to austenite. At X3 the alloy consists of uniform solid solution of austenite as shown in fig.2.8c. On slow cooling of alloy from X3 nothing happens until 'Acm' line is crossed at X4. Above X4 austenite is an unsaturated solid solution. At X4 austenite is saturated with carbon. As the temperature is decreased, carbon content of austenite (maximum amount of carbon that be dissolved in austenite) decreases along grain boundaries. The micro structure of alloy at X5 is shown in fig.2.8d. On further cooling of alloy, once temperature of alloy crosses lower critical temperature line ('PSK' line) at X7 the austenite present in the alloy undergoes eutectoid reaction and gets converted into pearlite. Just below A3.1, line ('SK' line) at microstructure of alloy shows around 96% pearlite and continuous network of cementite (around 4%) as shown fig 2.8e.

Plain Carbon Steels:

The usual composition of plain carbon steel is as follows

Carbon 0.08 to 1.7%; Mn 0.3 to 1.0%; silicon 0.05 to 0.3%; Sulphur 0.05(max); Phosphorus
%(max)

In plain carbon steels, carbon percentage plays a vital role in deciding the properties of steels. Depending on the carbon percentage plain carbon steels are divided into three types.

a. Low carbon steel (Mild steel) b. Medium carbon steel c. High Carbon steel

The microstructure of low carbon steel (Mild Steel) consists of single phase ferrite, (equi axial grains) i.e., it doesn't respond much to the heat treatment. The properties don't vary to any treatment given to the mild steel. It remains mild.

4The following specimens are to be studied for their Microstructures in this exercise

a. Mild Steel

Specimen : Mild Steel

Composition : Very low carbon(0.05%), remaining
iron

Heat treatment : Nil

Etchant : Nital

Etching time : 10 seconds

The structure is single phase equiaxed grains of ferrite.

Application: nuts, bolts, rivets, shafts etc.

b. Hypo eutectoid steel:

Specimen	:	Hypo eutectoid steel
Composition	:	0.5% carbon, remaining iron
Heat treatment	:	Nil
Etchant	:	Nital
Etching time	:	10 Seconds

The microstructure shows ferrite and pearlite.

c. Eutectoid steel:

Specimen	:	Eutectoid steel
Composition	:	0.8% carbon, remaining iron
Heat treatment	:	Nil
Etchant	:	Natal
Etching time	:	10 Seconds

The microstructure of eutectoid steel consists of 100% pearlite

d. Hyper eutectoid steel

Specimen	:	Hyper eutectoid steel(High carbon steel)
Composition	:	1% carbon, remaining iron
Heat treatment	:	Nil
Etchant	:	Natal
Etching time	:	10 Seconds

The microstructure shows continuous network of cementite along the grain boundaries of coarse pearlite.

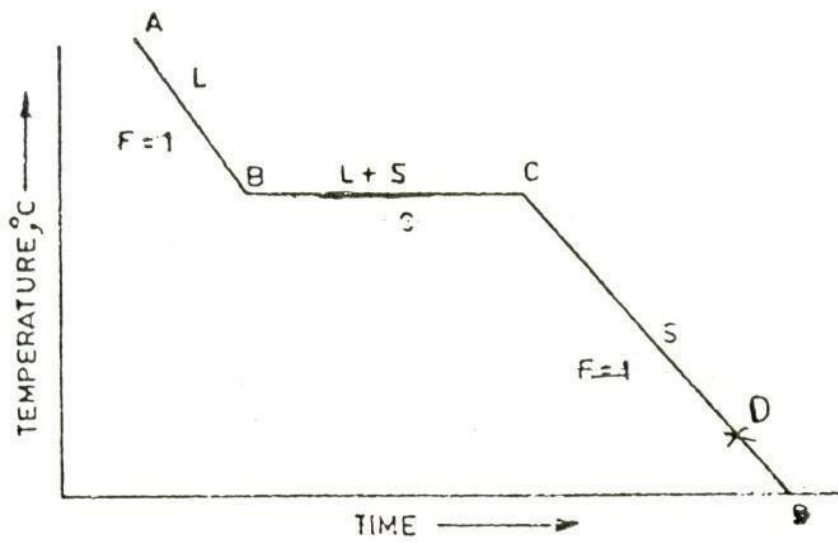

Cooling curve of a pure metal.

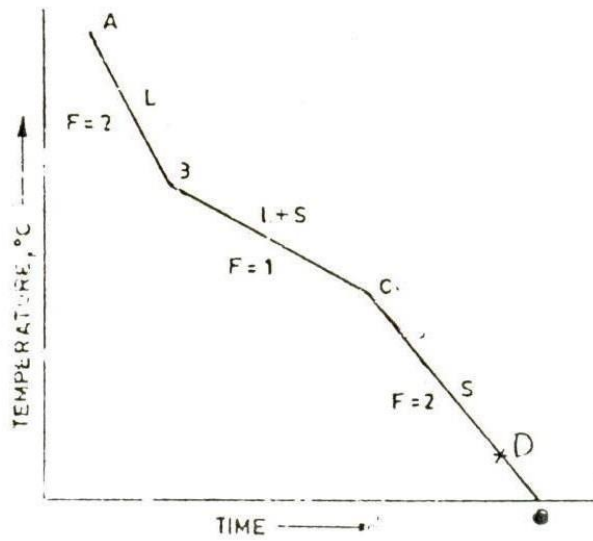

Cooling curve of a solid solution alloy.

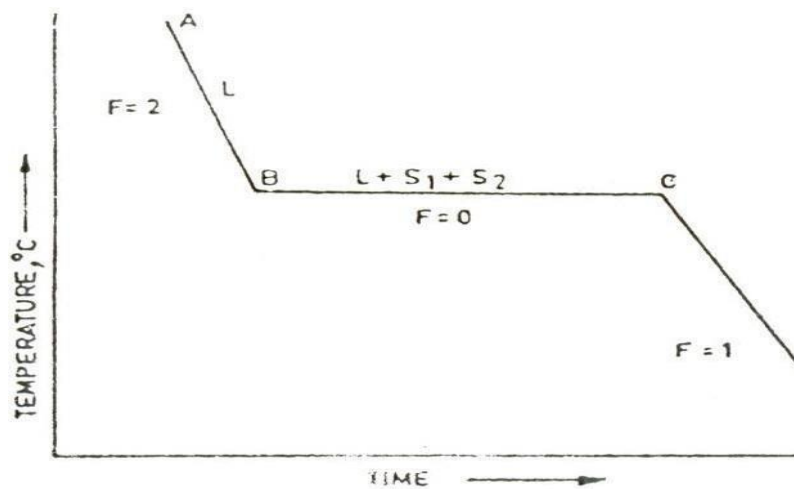

Cooling curve of an eutectic alloy

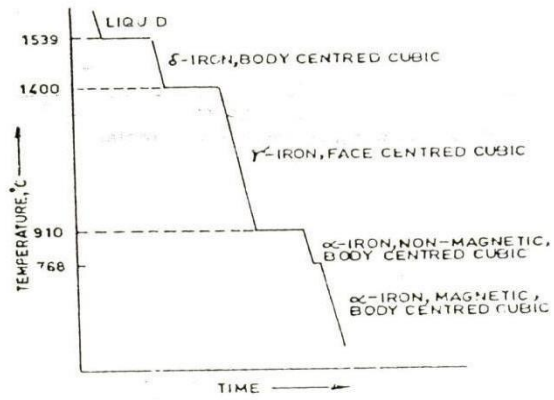

Fig. 2.4 Cooling curve of pure iron

Cooling curve of pure Iron

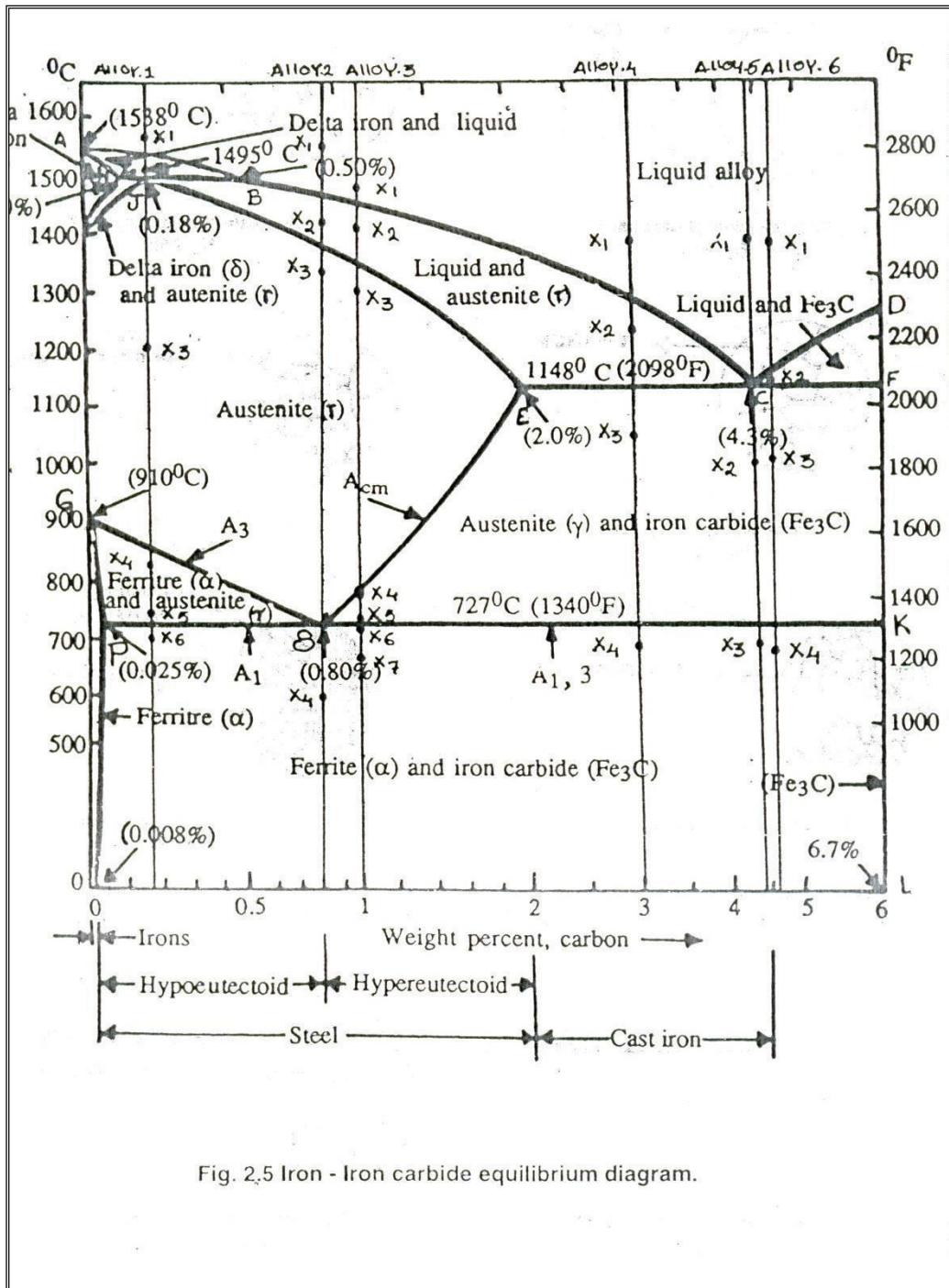

Fig. 2.5 Iron - Iron carbide equilibrium diagram.

Iron-Iron carbide equilibrium diagram

EXPERIMENT No. 04

To the study of Microstructure Heat treated steels.

Aim: To identify the different phases and to draw the microstructures Heat treated plain carbon steel.

1. Apparatus and specimens required:

Metallurgical microscope, specimen of high carbon steel subjected to annealing, normalizing, hardening and Hardening & tempering.

2. Theory:

Heat Treatment: It involves heating the metal to a suitable temperature within the solid state, maintaining the sample at that temperature for a specified period of time and cooling it to room temperature in a controlled manner.

The purpose of heat treatment may be

- To relieve internal stresses and soften the metal for further deformation.
- To refine the grain size improve mechanical properties.
- To alter the surface condition
- To increase corrosion and wear resistance.

3.1.1 Different Heat treatment processes are:

- a. Annealing b. Normalizing c. Hardening d. Tempering e. Surface hardening treatments

Time Temperature and Transformation Diagram(TTT diagram):

The TTT Diagram super imposed with different cooling austenitising temperature to room temperature is shown in fig.6.1

In fig. 6.1 V1 represents annealing (with slow cooling in the furnace) V2 represents normalizing (a little faster cooling i.e. in air)
V_c represents Critical cooling rate (more faster cooling in a bath of a mixture)
V5 represents Hardening (very fast cooling-dipping the specimen in oil or water)

Annealing:

The main purpose of annealing is stress relieving so that ductility of the steel can be improved to a greater extent. The annealing temperature range of steel is shown in fig.6.2

Annealing process cycle on Time-temperature diagram is shown in fig.6.4 Annealing process consists of

- a. Heating the specimen of steel to a temperature (above A₃ line in case of Hypo eutectoid steels and above A₃, line case of Hyper eutectoid steels)
 - b. Holding specimen at that temperature for a specified period of time (depending on the section thickness)
 - c. Then cooling the steel specimen to the room temperature in the furnace itself.
- The annealed structure of Hypo eutectoid steel consists of Ferrite and coarse pearlite.

Normalising: the purpose of Normalizing is to

- a. Relieve the internal stresses
- b. Refine the structure and improve the machinability. Normalising temperature range of steels is shown in fig.6.2 Normalizing process cycle Time-Temperature diagram is shown in fig. Normalizing process consists of
 - a. Heating the specimen of steel to a temperature (30 to 500°C above A₃ line in case of hypereutectoid steels and above A_{cm} line in case of hyper eutectoid steels.)

- b. Holding the specimen at this temperature for a specified period of Time.
- c. Then cooling the specimen to the room temperature in air. Normalized Hypo eutectoid steel consists of Ferrite and fine Pearlite.

Hardening: Main purpose of hardening is to improve the hardness & wear resistance of steels. Temperature range of hardening of steels is shown in fig.6.3

Hardening process cycle on Time-Temperature diagram is shown in fig. 6.6. Hardening process consists of

- a. Heating the steel specimen to a temperature (500C higher than A3 line in case of hypo eutectoid steel and around 500C higher than A3 line in case of hyper eutectoid steel)
- b. Holding at that temperature for sufficient period of time.
- c. Quenching in water or oil to cool the specimen of steel to room temperature. The microstructure of hardened hyper eutectoid steel consists of fine martensite embedded with carbon network.

Tempering: Main purpose of tempering are

- a. To reduce the thermal stresses.
- b. To stabilize the structure of metal.
- c. To reduce the hardness and brittleness.
- d. To increase ductility and toughness of hardened steel specimens. Tempering process cycle on Tim-Temperature diagram is shown in fig.6.7 Tempering process consists of heating the specimen to a temperature below lower critical temperature for sufficient period of time and then slowly cooling to room temperature.

Microstructure of hardened and tempered steel consists of Ferrite and finely divided cementite.

Case hardening: For certain application hard ware resistant case and tough core is required.

To get hard case and tougher core steels must be subjected to Case hardening treatment.

Case hardening methods:

Case hardening methods are broadly divided into two types.

- a. Methods of case hardening by altering the surface chemical composition of the components. examples of this type are (i) carburizing (ii) Nitriding (iii) Carbonitriding.
- b. Methods of case hardening without altering the surface chemical composition of the components. Examples of this type are (1) Flame hardening (2) induction hardening.

Methods of case hardening by altering surface chemical composition of the components

3.9.1 Carburizing: the method of increasing the carbon content on the surface of a steel is called carburizing. The process of carburizing consists of heating the steel in austenite region in contact with a carburizing medium, holding at his temperature for a sufficient period and cooling to room temperature.

Depending on the medium used for carburizing it is classified into three types (i) Pack carburizing (ii) Gas carburizing (iii) Liquid carburizing.

3.9.1 a) Pack carburizing : The components to be carburized are packed with a carbonaceous medium 9carbonaceous medium consists of hard wood charcoal, coke and energizer(barium carbonat0 in a box and sealed with clay. The box is heated to austenitic region and then cooled to room temperature.

3.9.1 b) Gas Carburizing: Here the components are heated in austenetic region in the presence of a carbonaceous gas such as methane, ethane with a carrier gas such as flue gas. These gases decompose and the carbon diffuses into steel.

c) Liquid Carburizing: in this method carburizing id done by immersing the steel components in a carbonaceous fused salt bath medium (bath is composed of 10% sodium cyanide, sodium carbonate

and sodium chloride) at a temperatures in the austenite region for sufficient time and then cooling to room temperature.

Nitriding: Nitriding is accomplished by heating steel in contact with a source of atomic nitrogen (ammonia gas) at a temperature of around 550⁰C for sufficient time and they cooling to room temperature. The atomic Nitrogen diffuses into steel and cambiues with iron and carbon alloying elements present in steel and form respective nitrides. These nitrides increase hardness and wear resistance of steels.

CarboNitriding: The components to be carbonitrided are heated in a fused salt bath or in a gaseous medium (gaseous medium contains carburizing gases like CH₄, C₂H₆ with 5 to 10% Ammonia) to a temperature between A₁ and A₃ temperatures of steel for sufficient period of time and are then cooled to room temperature. In this process both carbon and Nitrogen are diffused into the surface of steel.

Methods of case hardening without altering the surface chemical composition of components.

Flame hardening: This process consists of heating the surface layer of the component to above its upper critical temperature by means of oxyacetylene flame followed by water spray quenching or immersion quenching to transform austenite to martensite.

Induction Hardening: This process also increases surface hardness by heating and quenching a thin surface layer of components. Here heating is done by means of an induction coil.

The Micro structures of following specimens are studied in this exercise.

a. High carbon steel.

Specimen : High carbon steel
Composition : 1% carbon, remaining iron

Heat treatment :
Annealing
Etchant : Nital
Etching time : 10 seconds

The annealed structure of high carbon steel consists of continuous network of cements and pearlite.

b. High carbon steel.

Specimen : High carbon steel
Composition : 1% carbon, remaining iron
Heat treatment : Normalized
Etchant : Nital
Etching time : 10 seconds

The normalizing continuous network cementite is broken. The microstructure shows cementite and pearlite.

c. High carbon steel.

Specimen : High carbon steel
Composition : 1% carbon, remaining iron
Heat treatment : Hardened
Etchant : Nital
Etching time : 10 seconds

The microstructure consists of martensite and carbon network.

d. High Carbon steel

Specimen	:	High carbon steel
Composition	:	1% carbon, remaining iron
Heat treatment	:	Hardened & Tempered
Etchant	:	Nital
Etching time	:	10 seconds

The microstructure consists of tempered martensite and epsilon carbide.

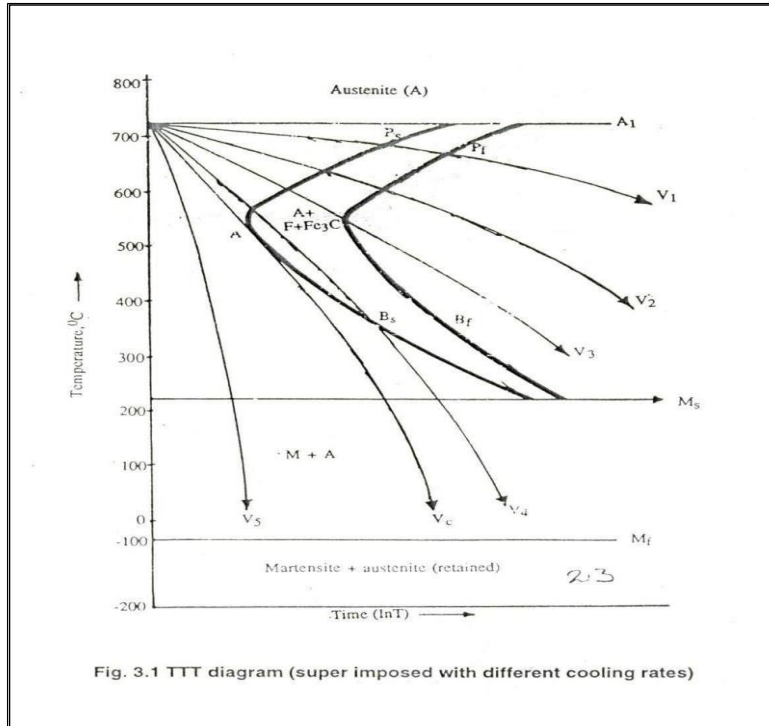

TTT diagram(super imposed with different cooling rates)

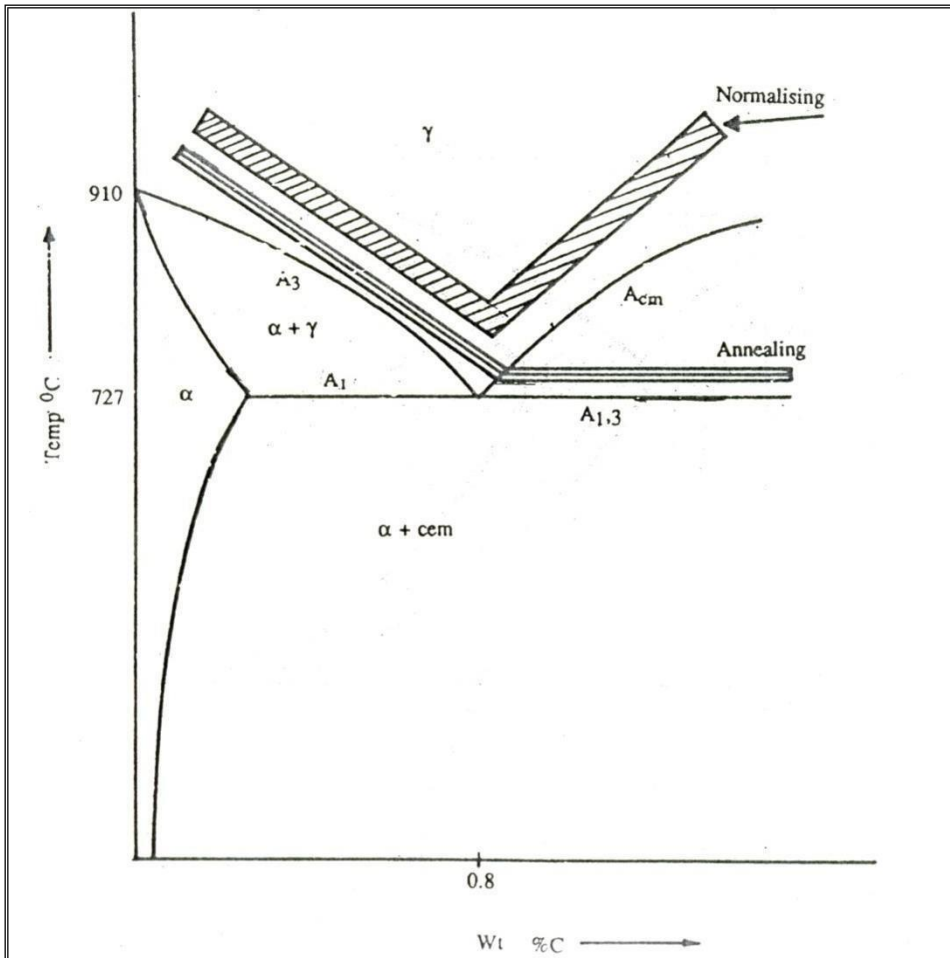

Fig. 3.2 Annealing and Normalising temperature ranges of steels

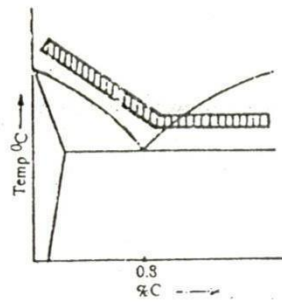

Fig. 3.3 Hardening temperature range of steels

Figure 4 Hardening temperature range of steels

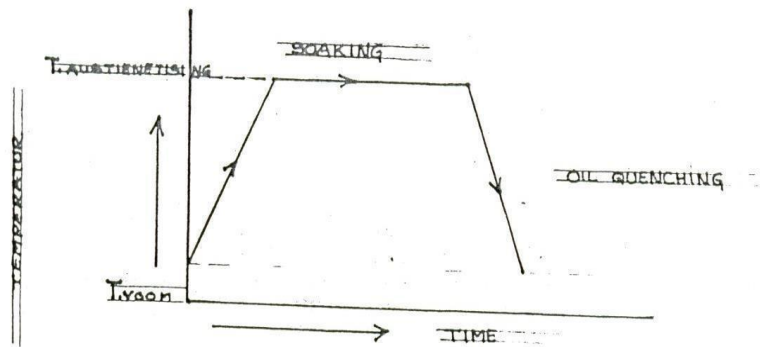

Fig. 3.6 Heat treatment cycle for Hardening on Time - Temperature diagrams for different types of steels

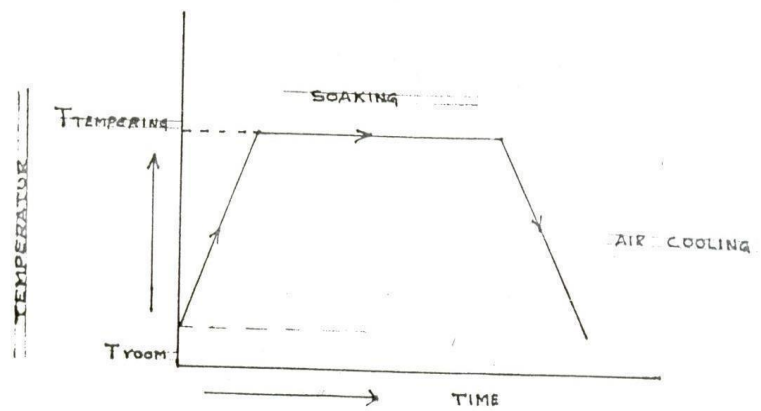

Fig. 3.7 Heat treatment cycle for tempering on Time - Temperature diagrams for different types of steels

Figure 5 Annealing and Normalising temperature ranges of steels

EXPERIMENT No. 05

STUDY OF MICROSTRUCTURE OF THE CAST IRONS

AIM:

To identify and draw the microstructures of Cast Iron specimens like Grey Cast Iron, White Cast Iron, Malleable Cast iron, and S.G. Cast iron etc.

APPARATUS:

- Given Specimens
- Belt Grinder
- Emery Papers (80,120,240,400,600 & 1000)
- Alumina Paste (Grade-1, 2 & 3)
- Disc Polishing Machines
- Suitable Etching Agents
- Air Blower
- Metallurgical Microscope

THEORY:

Cast irons contain 2 to 6.67 % of carbon. Since high carbon content tends to make the Cast iron very brittle, most commercially manufactured types are in the range of 2.5 to 4% of carbon. The ductility of Carbon is very low and it cannot be rolled, drawn or worked at room temperature. However they melt readily and can be cast to complicated shapes which are usually machined to final dimensions. Since the casting is only the suitable process applied to these alloys, they are known as cast irons.

Although the common cast irons are brittle and have lower strength properties than most steels, they are cheap, can cast more readily than steel and have other useful properties. In addition by proper alloying good foundry control and appropriate heat treatment is possible. The properties of any cast iron can be varied over a wide range.

WHITE CAST IRON:

In white cast iron most of the carbon is present in the combined forms as cementite. This is obtained by rapid cooling of the iron. White cast irons contain large amount of cementite as continuous inter dendritic network. It makes the cast iron hard, wear resistance but extremely brittle and difficult to machine.

White cast irons are limited in engineering applications because of brittleness and lack of machinability. They are used where resistant to wear is important and service does not require, such as cement mixer, ball mills certain types of drawing dies and extrusion nozzle. A large tonnage of white cast iron is used as a raw material for manufacture of malleable cast iron.

MALLEBLE CAST IRON:

In malleable cast iron most of the carbon is uncombined form of irregular particles known as tempered carbon. This is obtained by heating the white cast iron to 920 to 1000 degree centigrade for about 50 hours followed by slow cooling to room temperature. While on heating, the cementite structure tends to decompose into ferrite + tempered carbon (Graphite). The lubrication action of the graphite imparts high machinability to malleable cast iron and lower the melting point makes it much easier to cast than steel.

Malleable cast irons are tough, strong and shock resistant. The addition of copper and molybdenum in combination produces malleable cast iron of superior corrosion resistance and mechanical properties. The malleable cast iron is used for wide applications such as agricultural implements, automobile parts, man hole covers, rail road equipment gears, cams and pipe fittings etc.

The composition of typical malleable cast iron is as follows:

- Carbon: 2.9%
- Silicon: 1.15%
- Manganese: 0.6%
- Phosphorous: 0.15%
- Sulphur: 0.5%

GREY CAST IRON:

In grey cast iron most or all of the carbon is uncombined form of graphite flakes. The tendency of carbon to form as graphite flakes is due to increased silicon and carbon content and thereby decreasing the cooling rate.

It is a low melting alloy, having good cast ability and machanibility. It has low tensile strength, high compression strength and very low ductility. Grey cast iron has excellent damping capacity and is often used as base for machinery or any equipment subject to vibration. It is also used for machine tool bodies, pipes and agricultural implements. The presence of graphite flakes provides lubricating effect to sliding bodies.

The composition of typical grey cast iron is as follows

- Carbon: 2.8 to 3.6%
- Silicon: 1 to 2.75%
- Manganese: 0.4 to 1%
- Phosphorous: 0.1 to 1%
- Sulphur: 0.06 to 0.12%.

□

NODULAR CAST IRON: (SPHEROIDAL GRAPHITE CAST IRON)

Nodular cast iron is also known as ductile iron. Spheroidal graphite iron is a cast iron in which graphite is present as tiny balls or spheroids. The compact spheroids interrupt the continuity of the matrix much less than graphite flakes. This result in higher strength and toughness compared with a similar structure of grey cast iron.

Nodular cast iron differs from malleable cast iron in that it is usually obtained as a result of solidification and does not require heat treatment. The spheroids are more rounded than irregular aggregates of temper carbon found in malleable cast iron. The formation of spherical graphite is due to addition of magnesium to the molten grey iron.

The composition of typical S.G.cast iron is as follows:

- Carbon : 3 to 3.5%
- Silicon : 2 to 2.5%
- Manganese : 0.15 to 0.6%
- Phosphorous : 0.025 to 0.4%
- Sulphur : 0.015 to 0.04 %

PROCEDURE:

1. Polish the specimen by using belt grinding machine.
2. Polish the specimen by using (80,120,240,400,600 & 1000) grade emery papers.
3. Polish the specimen by using (1/0, 2/0, 3/0, 4/0,) grade emery papers.
4. Subject the given specimen to mirror like finish by using disc polishing machine and with suitable abrasive.
5. Clean the specimen with alcohol and wash it under the stream of flowing water.
6. After washing the specimen is dried. After drying apply the suitable etching agent for 30 to 50 sec.
7. After etching wash the specimen under stream of flowing water.
8. Dry the specimen with the help air drier.
9. Place the specimen for metallurgical studies.
10. Draw the microstructure and analyze the properties

APPLICATIONS:

Agricultural tractor and implement parts, automotive and diesel crank shafts, piston and cylinder heads, electrical fittings, motor frames, hoist drums, flywheels and elevator buckets, steel mill, furnace doors and bearings wrenches levers and handles.

RESULT:

EXPERIMENT No. 06

STUDY OF MICROSTRUCTURE OF NON-FERROUS ALLOYS

AIM:

To study the microstructures of Nonferrous alloy specimens like Al, Cu alloys and bearing metal.

APPARATUS:

- Given Specimens
- Belt Grinder
- Emery Papers (80,120,240,400,600 & 1000)
- Alumina Paste (Grade-1, 2 & 3)
- Disc Polishing Machines
- Suitable Etching Agents
- Air Blower
- Metallurgical Microscope

THEORY:

Nonferrous metals and alloys contain other than iron as a main constituent. They exhibit different properties compared to ferrous metals and alloys. Hence their application also differs from ferrous metals. We shall study the microstructures of Al, Cu, and alloys.

CU- ALLOYS

BRASS:

Brasses are the copper alloys containing zinc up to 30% they possess relatively good corrosion resistance and good working properties. They also possess high ductility hence they are suitable for drastic cold working. In common to relieve the stresses annealing is done. Most normally used brass contains 30% zinc and 70% copper which is known as cartridge brass. This shows higher ductility and malleability. The microstructure shows a typical equi axied grain structure with twins in annealed structure. This brass is used for making cartridge cases. Other applications includes radiator cases, head light reflectors, hardware, and plumbing accessories.

AL-ALLOYS:

Aluminum alloy contains silicon up to 12 %. Aluminum- silicon is also called as silumin.

There are two types of aluminum silicon alloys, they are:

LM-6:

It contains above 12% silicon due to its higher corrosion resistance and fluidity. It is used in water cooled marine tools for pump parts.

LM-13

It contains silicon up to 12.5%, Ni 2.5%, ca 1% and Mg 12%. This shows good forgability and low coefficient of thermal expansion. It is used in automobile pistons.

BEARING METAL:

Bearing metal has high compressive strength and high wear resistance, high fatigue strength and better thermal conductivity for heat dissipation, corrosion resistance and good machinability. They have hard and soft phases. Most widely used bearing metal is a Babbitt metal. They are called as low melting bearing alloy. Lead based and tin based Babbitt contain Antimony as most popular this group.

PROCEDURE:

1. Polish the specimen by using (1/0, 2/0, 3/0, 4/0,) grade emery papers.
2. Subject the given specimen to mirror like finish by using disc polishing machine and with suitable abrasive.
3. Clean the specimen with alcohol and wash it under the stream of flowing water
4. After washing the specimen is dried. After drying apply the suitable etching agent for 30 to 50 sec.
5. After etching wash the specimen under stream of flowing water.
6. Dry the specimen with the help air drier.
7. Place the specimen for metallurgical studies.
8. Draw the microstructure and analyze the properties

PRECAUTIONS:

- 1) Polishing should be slow, smooth and flat
- 2) Uniform pressure is applied throughout the polishing
- 3) Proper Care should be Taken While Etching.
- 4) Wash Your Hands Thoroughly After Experiment.

RESULT:

