

**DEPARTMENT OF
MECHANICAL ENGINEERING**

LABORATORY MANUAL

**MECHANICAL ENGINEERING
(CSMSS/ENGG/MECH/TDLAB/TD/BTMCL606)**



**CSMSS
CHH. SHAHU COLLEGE OF ENGINEERING
KANCHANWADI, CHHATRAPATI SAMBHAJINAGAR - 431011**

	CSMSS		LABORATORY
	CHH. SHAHU COLLEGE OF ENGINEERING		MANUAL
COURSE OUTCOMES			
DEPARTMENT: MECHANICAL ENGINEERING			
LABARATORY NAME: TERMODYNAMICS LAB			
LABORATORY MANUAL NO.:1		SEMESTER: VI	YEAR: 2024-25
CSMSS/ENGG/MECH/FMLAB/TD/BTMCL606			
COURSE NAME: APPLIED THERODYNAMICS LAB		ISSUE DATE: 22/07/2024	PAGE: 1 OF 2

Course Name: APPLIED TERMODYNAMICS LAB

Course Code: BTMCL606

Examination Scheme:

1. **Internal Assessment:** 60 Marks (CA1 = 30 Marks and CA2 = 30 Marks)
2. **External Assessment:** 40 Marks

Course Outcomes:

After successfully completion the course, the students will be able to:		Blooms Level
CO1	Students will be able to determine the calorific value by Bomb calorimeter	Apply
CO2	Students will be able to take measurement of dryness fraction of steam using separating & throttling calorimeter.	Apply
CO3	Students will be able to do flue gas analysis using emission measuring instruments	Analyze
CO4	Students will be able to demonstrate different types of Boilers.	Understand
CO5	Students will be able to take trail on single & two stage reciprocating compressor.	Apply

	CSMSS CHH. SHAHU COLLEGE OF ENGINEERING	LABORATORY MANUAL
	MASTER LIST OF EXPERIMENTS	
DEPARTMENT: MECHANICAL ENGINEERING		
LABORATORY NAME: THERMODYNAMICS LAB		
LABORATORY MANUAL NO.:1 CSMSS/ENGG/MECH/TD LAB/TD/ BTMCL606	SEMESTER: VI	YEAR: 2024-25
COURSE NAME: APPLIED THERMODYNAMICS LAB	ISSUE DATE: 22/07/2024	PAGE: 2 OF 2

MASTER LIST OF EXPERIMENT

SR. NO.	EXPERIMENT NO.	EXPERIMENT TITLE	PAGE NO.
1	01	Determination of calorific value by Bomb calorimeter	
2	02	Measurement of dryness fraction of steam using separating & throttling calorimeter.	
3	03	Trial on boiler	
4	04	Flue gas analysis using emission measuring instruments	
5	05	Study & trial on single stage/two-stage reciprocating air compressor	

PREPARED BY:  Prof. B.M. Netake Course Teacher	CHECKED BY:  Prof. V.G. Kokre Lab In-charge	VERIFIED BY:  Department Review Committee	APPROVED BY:  Dr. R.H. Shinde HOD
---	--	---	--

	CHH. SHAHU COLLEGE OF ENGINEERING, AURANGABAD		LABORATORY MANUAL
	PRACTICAL EXPERIMENT INSTRUCTION SHEET		
	EXPERIMENT TITLE: Determination of C.V. of solid fuels by using (Bomb) calorimeter.		
DEPARTMENT:MECHANICAL ENGINEERING		LABORATORY :CSMSS/ENGG/MECH/TD LAB	
LABORATORY MANUAL NO.:CSMSS/ENGG/MECH/TD-01		YEAR:2016-17	
Class: Second Year	PART: I	SUBJECT: Thermodynamics- I	PAGE: ¹ OF 4

Aim:

Determination of C.V. of solid fuels by using (Bomb) calorimeter.

Construction:

1. The bomb is a thick walled constant volume vessel made of stainless steel which provides considerable resistance to corrosion and can withstand a pressure of about 150 atmospheres.
2. The unit has a silica crucible in which is placed a weighed quantity of the fuel sample.
3. The bomb is provided with an electric connection for producing spark, a connection for oxygen supply and a release valve for burnt gases.
4. The bomb is surrounded by jacket containing water.
5. The temperature of this water is kept uniform with the help of a motor driven stirrer.
6. The water temperature is measured by a special thermometer reading up to 0.01 degree.



	CHH. SHAHU COLLEGE OF ENGINEERING, AURANGABAD		LABORATORY MANUAL
	PRACTICAL EXPERIMENT INSTRUCTION SHEET		
EXPERIMENT TITLE: Determination of C.V. of solid fuels by using (Bomb) calorimeter.			
DEPARTMENT:MECHANICAL ENGINEERING		LABORATORY :CSMSS/ENGG/MECH/TD LAB	
LABORATORY MANUAL NO.:CSMSS/ENGG/MECH/TD-01		YEAR:2016-17	
Class: Second Year	PART: I	SUBJECT: Thermodynamics- I	PAGE: 2 OF 4

Figure: Bomb Calorimeter

BOMB CALORIMETER

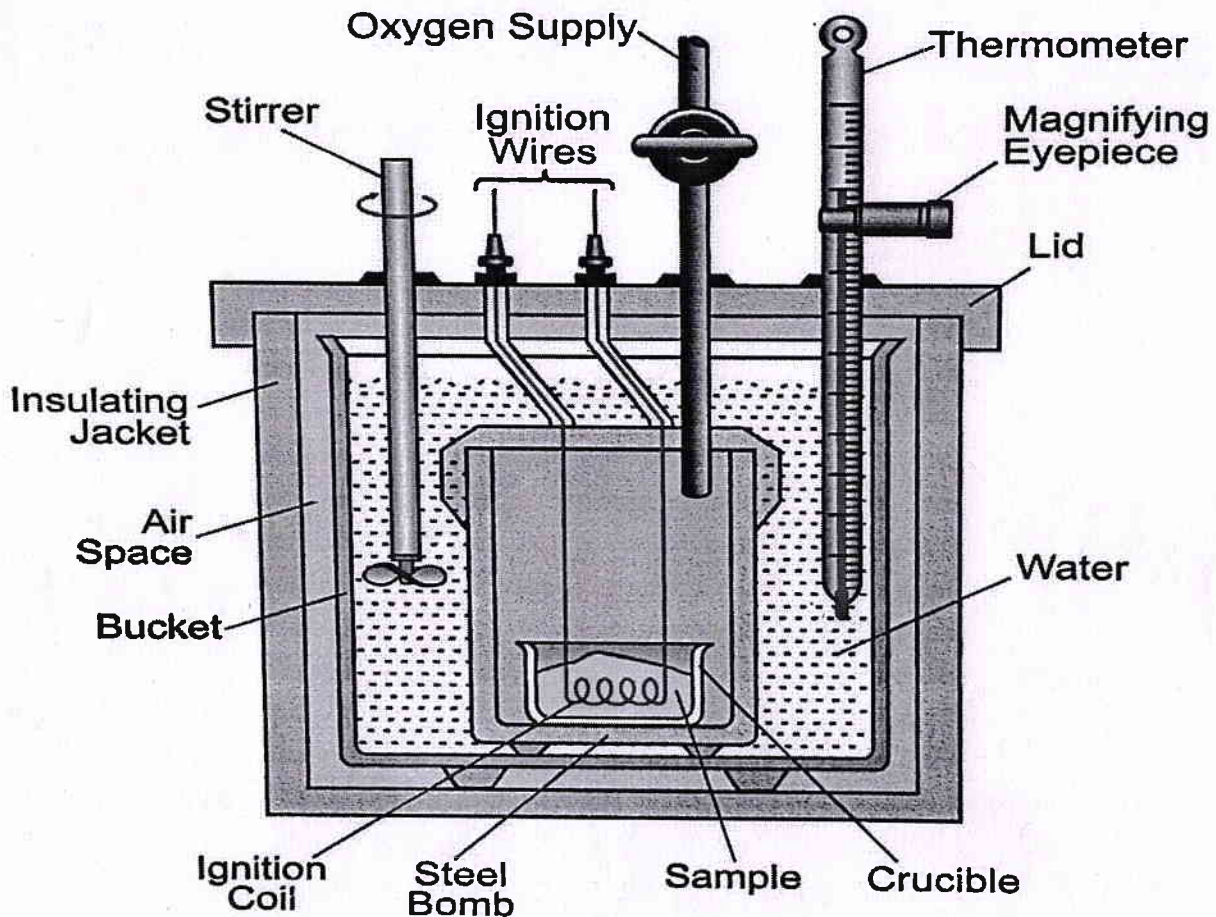

	CHH. SHAHU COLLEGE OF ENGINEERING, AURANGABAD		LABORATORY MANUAL
	PRACTICAL EXPERIMENT INSTRUCTION SHEET		
EXPERIMENT TITLE: Determination of C.V. of solid fuels by using (Bomb) calorimeter.			
DEPARTMENT:MECHANICAL ENGINEERING		LABORATORY :CSMSS/ENGG/MECH/TD LAB	
LABORATORY MANUAL NO.:CSMSS/ENGG/MECH/TD-01		YEAR:2016-17	
Class: Second Year	PART: I	SUBJECT: Thermodynamics- I	PAGE: ³ OF 4

Procedure:-

1. A fuel pallet (benzoic acid tablet) of 0.75 to 1 gm is accurately weighted and placed in the crucible.
2. A fuse wire of known mass is stretched between the electrodes and it is ensured that the fuse wire is in contact with the fuel.
3. The oxygen required for burning of fuel is admitted in the bomb through oxygen valve to a pressure of about 25-30 bar.
4. The bomb is placed in the calorimeter (water jacket) which contains a measured quantity of distilled fuel.
5. The water in the calorimeter is simultaneously stirred at moderate rate and temperature readings are noted.
6. When the temperature becomes constant, the electric circuit is closed and the fuel gets ignited.
7. Due to combustion of fuel, heat is liberated and the temperature of water starts rising.
8. Temperature readings are noted at regular intervals until constantancy is observed.
9. Having completed the experiment, the bomb is removed from the calorimeter. The pressure is slowly released through the exhaust valve and the contents of the bomb are weighed.



CHH. SHAHU COLLEGE OF ENGINEERING, AURANGABAD

LABORATORY
MANUAL

PRACTICAL EXPERIMENT INSTRUCTION SHEET

EXPERIMENT TITLE: Determination of C.V. of solid fuels by using (Bomb) calorimeter.

DEPARTMENT:MECHANICAL ENGINEERING

LABORATORY :CSMSS/ENGG/MECH/TD LAB

LABORATORY MANUAL
NO.:CSMSS/ENGG/MECH/TD-01

YEAR:2016-17

Class: Second
Year

PART: I

SUBJECT: Thermodynamics- I

PAGE: 4 OF 4

Observation table:

Sr. No.	Mass of solid fuel	Mass of water	Water .	
			Initial Temperature(°C)	Final Temperature(°C)

Calculations:-

$$m_f \times CV = m_w C_p (\Delta t)$$

Result:-

The calorific value of given solid fuel using Bomb calorimeter is _____.

	CHH. SHAHU COLLEGE OF ENGINEERING, AURANGABAD		LABORATORY MANUAL
	PRACTICAL EXPERIMENT INSTRUCTION SHEET		
EXPERIMENT TITLE: Determination of C.V. of gaseous fuels by using (Junker's) calorimeter.			
DEPARTMENT:MECHANICAL ENGINEERING		LABORATORY :CSMSS/ENGG/MECH/TD LAB	
LABORATORY MANUAL NO.:CSMSS/ENGG/MECH/TD-02		YEAR:2016-17	
Class: Second Year	PART: I	SUBJECT: Thermodynamics- I	PAGE: 1 OF 4

Aim:-

Determination of C.V. of gaseous fuels by using (Junker's) calorimeter.

Construction:-

The unit essentially comprises:

1. A gas meter with thermometer attached to it.
2. A gas pressure regulator.
3. A suitable burner which is placed inside the combustion chamber. The combustion chamber is surrounded by water jacket through which pass a set of tubes called flues.
4. A set of accurate thermometers fitted at appropriate places for measurement of cold water and hot water.

Figure: Junker's Calorimeter

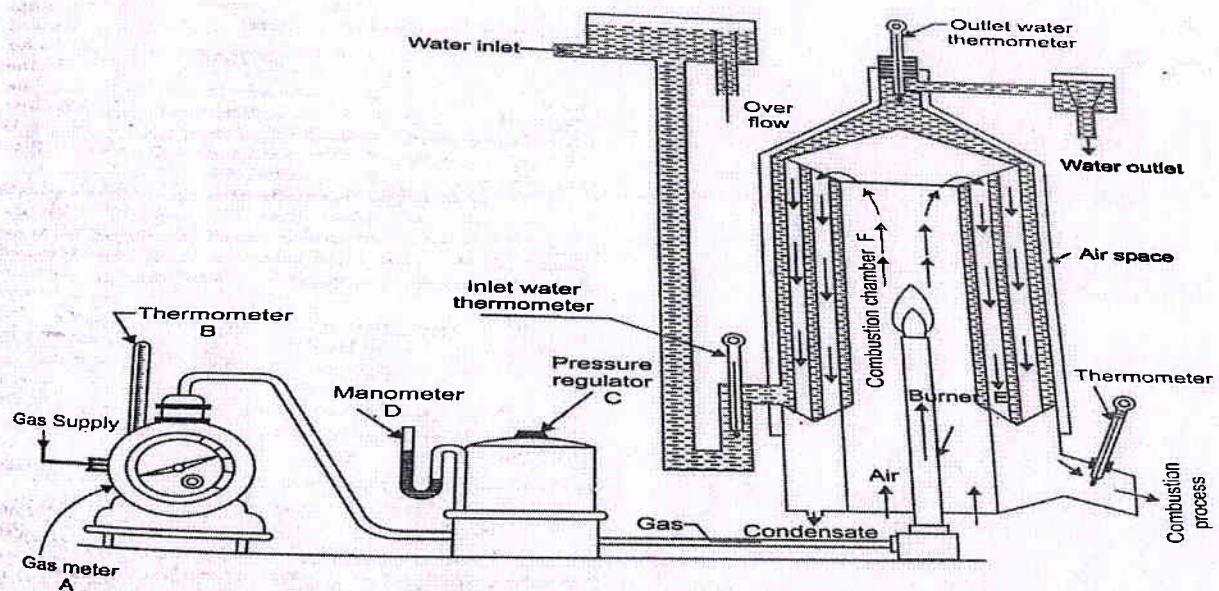

	CHH. SHAHU COLLEGE OF ENGINEERING, AURANGABAD		LABORATORY MANUAL
	PRACTICAL EXPERIMENT INSTRUCTION SHEET		
	EXPERIMENT TITLE: Determination of C.V. of gaseous fuels by using (Junker's) calorimeter.		
DEPARTMENT:MECHANICAL ENGINEERING		LABORATORY :CSMSS/ENGG/MECH/TD LAB	
LABORATORY MANUAL NO.:CSMSS/ENGG/MECH/TD-02		YEAR:2016-17	
Class: Second Year	PART: I	SUBJECT: Thermodynamics- I	PAGE: ² OF 4

Operation:-

1. A gas burner is supplied with a metered quantity of gas whose calorific value is to be estimated.
2. The gas first passes through the governor and it is so adjusted that uniform flow rate of gas is ensured.
3. Subsequently gas passes through the gas flow meter where its volume is metered.
4. When the gas burns, the hot products of combustion travels upwards through the centre of the chamber. The chamber is so designed that the gases after having reached the top get deflected downwards through the flues and finally escape to the atmosphere through outlet.
5. The water enters the jacket, surrounding the combustion chamber, at the bottom and leaves from the top. The water which flows through the jacket is collected, weighed and its temperature at inlet and outlet are noted.

Procedure:-

1. Connect the water supply from the overhead tank or water tap to water inlet of apparatus.
2. Turn on the water mains by opening the water tap to the gas calorimeter. Adjust water supply in such a way that there will be only a small amount of overflow of excess water to sink. By this the air bubbles inside the water circulating will be let out.
3. Remove the burner from the calorimeter.
4. Turn On the regulator valve of LPG cylinder and allow the gas to pass through governor and subsequently to the flow meter. Allow the gas to pass for three four revolutions as indicated by the flow-meter.
5. Now light the burner and adjust the air regulator sleeves and the gas tap to get a non-luminous flame.

	CHH. SHAHU COLLEGE OF ENGINEERING, AURANGABAD		LABORATORY MANUAL
	PRACTICAL EXPERIMENT INSTRUCTION SHEET		
	EXPERIMENT TITLE: Determination of C.V. of gaseous fuels by using (Junker's) calorimeter.		
DEPARTMENT:MECHANICAL ENGINEERING		LABORATORY :CSMSS/ENGG/MECH/TD LAB	
LABORATORY MANUAL NO.:CSMSS/ENGG/MECH/TD-02		YEAR:2016-17	
Class: Second Year	PART: I	SUBJECT: Thermodynamics- I	PAGE: ³ OF 4

6. Clamp the burner by keeping it to top most position.
7. Allow the water outlet temperature indicator to indicate a steady temperature which may take about 20 to 30 minutes.
8. Keeping the measuring jar beneath the swinging water outlet tube and simultaneously count the number of revolutions made by gas flow-meter pointer i.e to find the volume of gas consumed during the test period.
9. Also immediately note the temperatures of water inlet and outlet by keeping the water flow and gas flow same.

Observation Table:-

Sr. No.	Water		Hot or outlet	Flow-meter reading	Time Period (seconds)
	Inlet temperature (°C)	Outlet temperature (°C)	Water Quantity measured		

	CHH. SHAHU COLLEGE OF ENGINEERING, AURANGABAD		LABORATORY MANUAL
	PRACTICAL EXPERIMENT INSTRUCTION SHEET		
	EXPERIMENT TITLE: Determination of C.V. of gaseous fuels by using (Junker's) calorimeter.		
DEPARTMENT:MECHANICAL ENGINEERING		LABORATORY :CSMSS/ENGG/MECH/TD LAB	
LABORATORY MANUAL NO.:CSMSS/ENGG/MECH/TD-02		YEAR:2016-17	
Class: Second Year	PART: I	SUBJECT: Thermodynamics- I	PAGE: 4 OF 4

Calculations:-

$$V_f \times CV = V_w \times C_{p_w} \times (T_{outlet} - T_{inlet})$$

Result:-

The calorific value of given LPG gas Junker's gas calorimeter is _____.

	CHH. SHAHU COLLEGE OF ENGINEERING, AURANGABAD		LABORATORY MANUAL
	PRACTICAL EXPERIMENT INSTRUCTION SHEET		
	EXPERIMENT TITLE: Study of determination of dryness fraction of steam.		
DEPARTMENT:MECHANICAL ENGINEERING		LABORATORY :CSMSS/ENGG/MECH/TD LAB	
LABORATORY MANUAL NO.:CSMSS/ENGG/MECH/TD-03		YEAR:2016-17	
Class: Second Year	PART: I	SUBJECT: Thermodynamics- I	PAGE: 1 OF 8

Aim:-

Study of determination of dryness fraction of steam.

Introduction:-

It is necessary to determine the quality of steam in order to ascertain the actual state of the wet steam. Knowledge of the state of the steam is necessary in any engineering application where steam is used as working fluid.

Now consider the flow of steam through a pipe, its temperature and pressure may be directly measured with the help of thermometer and pressure gauge. If the observed temperature is above saturation temperature of steam (known from steam tables as pressure is known), then it is also known that the vapour is in superheated condition. On the hand, if the observed temperature corresponds to the saturated temperature of steam at the observed pressure, then steam may be saturated or wet. The state may be anything from saturated liquid to dry and saturated steam. Under these conditions, it is always necessary to find the quality of steam before calculating other properties of steam. The Quality of steam is designated by the dryness fraction of the steam and it is experimentally measured.

The dryness fraction of steam is defined as the ratio of the mass of dry steam present in the total mass of steam.

$$X = \frac{m_s}{m_s + m_w}$$

Where m_s and m_w are the masses of steam and water in the mixture of $(m_s + m_w)$.

	CHH. SHAHU COLLEGE OF ENGINEERING, AURANGABAD		LABORATORY MANUAL
	PRACTICAL EXPERIMENT INSTRUCTION SHEET		
	EXPERIMENT TITLE: Study of determination of dryness fraction of steam.		
DEPARTMENT:MECHANICAL ENGINEERING		LABORATORY :CSMSS/ENGG/MECH/TD LAB	
LABORATORY MANUAL NO.:CSMSS/ENGG/MECH/TD-03		YEAR:2016-17	
Class: Second Year	PART: I	SUBJECT: Thermodynamics- I	PAGE: 2 OF 8

Theory:-

Separating calorimeter

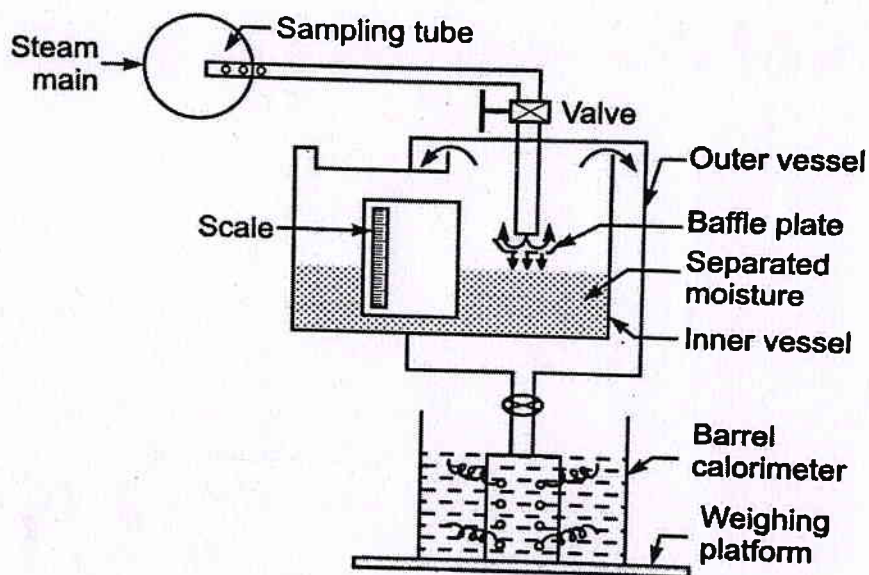



Figure: Separating Calorimeter

This calorimeter is used to measure the probable value of dryness fraction of steam when the steam is very wet.

The arrangement of the calorimeter is shown in fig. The steam is passed through a sample of tube as shown in fig. The moisture is separated mechanically from the steam. The steam is passed

	CHH. SHAHU COLLEGE OF ENGINEERING, AURANGABAD		LABORATORY MANUAL
	PRACTICAL EXPERIMENT INSTRUCTION SHEET		
	EXPERIMENT TITLE: Study of determination of dryness fraction of steam.		
DEPARTMENT:MECHANICAL ENGINEERING		LABORATORY :CSMSS/ENGG/MECH/TD LAB	
LABORATORY MANUAL NO.:CSMSS/ENGG/MECH/TD-03		YEAR:2016-17	
Class: Second Year	PART: I	SUBJECT: Thermodynamics- I	PAGE: 3 OF 8

through perforated trays and the water particles are separated due to inertia of the droplets. The outgoing steam is condensed in the bucket calorimeter.

m_w = mass of water separated from the steam

m_s = mass of steam condensed in the bucket calorimeter which can be calculated by difference in mass of the bucket calorimeter before and after mixing the steam.

X = dryness fraction of steam

$$X = \frac{m_s}{m_s + m_w}$$

In calculating the dryness fraction of steam by this method, it is assumed that all the water particles are removed in separating section and the steam entering in the bucket calorimeter is completely dry.

	CHH. SHAHU COLLEGE OF ENGINEERING, AURANGABAD		LABORATORY MANUAL
	PRACTICAL EXPERIMENT INSTRUCTION SHEET		
	EXPERIMENT TITLE: Study of determination of dryness fraction of steam.		
DEPARTMENT:MECHANICAL ENGINEERING		LABORATORY :CSMSS/ENGG/MECH/TD LAB	
LABORATORY MANUAL NO.:CSMSS/ENGG/MECH/TD-03		YEAR:2016-17	
Class: Second Year	PART: I	SUBJECT: Thermodynamics- I	PAGE: 4 OF 8

Throttling Calorimeter

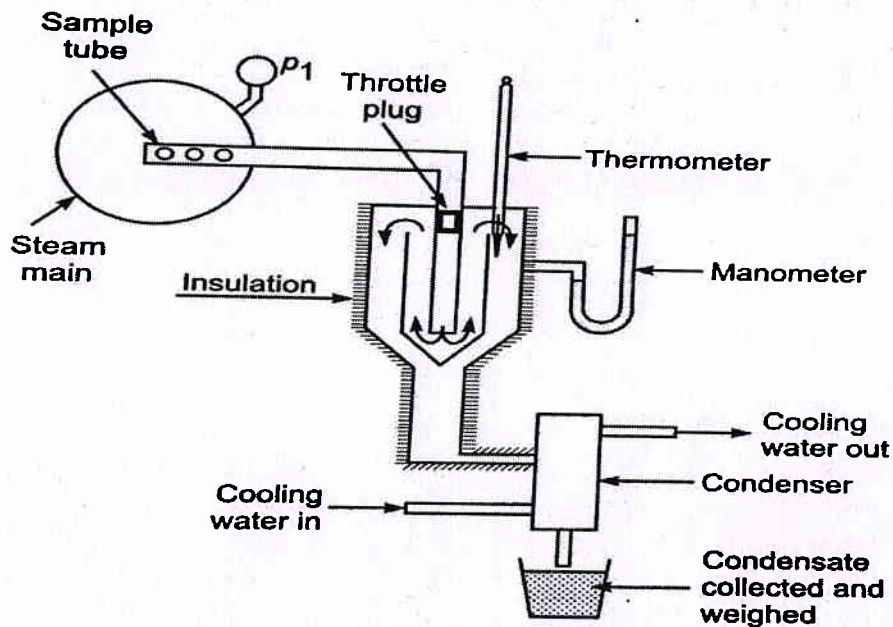



Figure: Throttling Calorimeter

The arrangement of this calorimeter is shown in fig. The steam whose dryness fraction is to be determined is taken into the calorimeter through a sample tube and passed through a throttle valve as shown in fig. The steam is allowed to throttle down to a lower pressure until it comes out in superheated condition. The pressure and temperature of steam coming out of the throttling valve are measured with the help of manometer and a thermometer.

	CHH. SHAHU COLLEGE OF ENGINEERING, AURANGABAD		LABORATORY MANUAL
	PRACTICAL EXPERIMENT INSTRUCTION SHEET		
	EXPERIMENT TITLE: Study of determination of dryness fraction of steam.		
DEPARTMENT:MECHANICAL ENGINEERING		LABORATORY :CSMSS/ENGG/MECH/TD LAB	
LABORATORY MANUAL NO.:CSMSS/ENGG/MECH/TD-03		YEAR:2016-17	
Class: Second Year	PART: I	SUBJECT: Thermodynamics- I	PAGE: 5 OF 8

Separating and Throttling Calorimeter

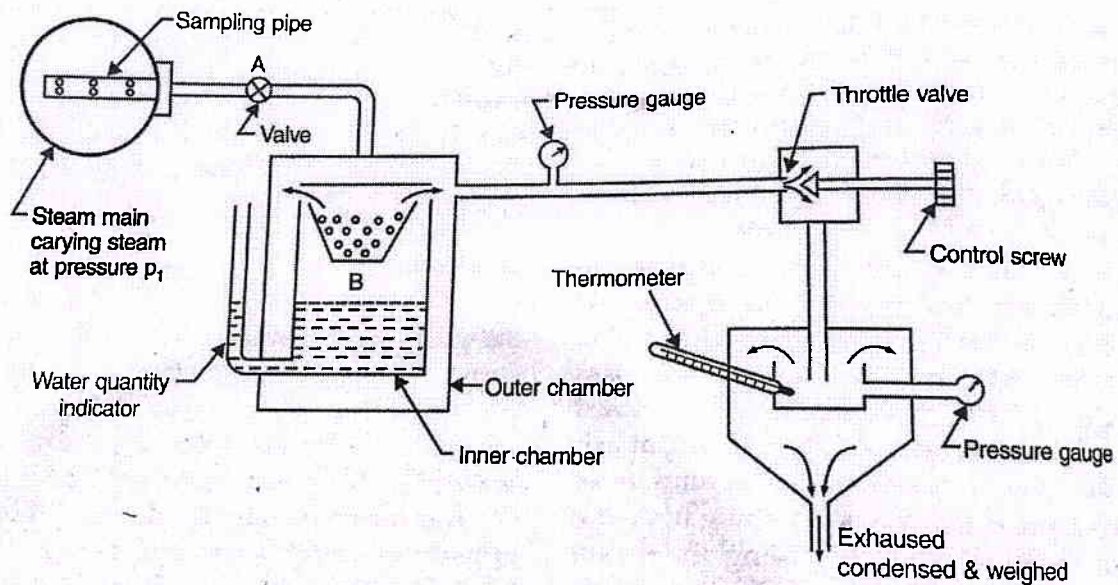



Figure: Separating and Throttling Calorimeter

The arrangement of separating and throttling calorimeter is shown in fig. where these calorimeters are placed in series. The steam from the sample tube is first passed through the separating calorimeters where major part of the water particles is removed and then it is passed onto the throttling calorimeter. The steam leaving the throttling valve comes out as superheated steam. The steam coming out of the throttling calorimeter is condensed in a condenser and mass of condensate is recorded. The mass of the water separated in separating calorimeter and the pressure and temperature of the steam leaving the throttle valve are recorded with the help of pressure gauge and mercury in glass thermometer.

	CHH. SHAHU COLLEGE OF ENGINEERING, AURANGABAD		LABORATORY MANUAL
	PRACTICAL EXPERIMENT INSTRUCTION SHEET		
	EXPERIMENT TITLE: Study of determination of dryness fraction of steam.		
DEPARTMENT:MECHANICAL ENGINEERING		LABORATORY :CSMSS/ENGG/MECH/TD LAB	
LABORATORY MANUAL NO.:CSMSS/ENGG/MECH/TD-03		YEAR:2016-17	
Class: Second Year	PART: I	SUBJECT: Thermodynamics- I	PAGE: ⁶ OF 8

Observation table:-

Sr.No.	Boiler Pressure	Separating Section		Throttling Section		
		Steam pressure 'P1' bar	Rate of steam separation 'W' Kg/sec	Steam Pressure 'P2' bar	Steam Temperature 'Tsup' °C	Rate of steam condensed 'Ws' kg/sec

Calculations:-

m_s = mass of steam condensed and collected from condenser

m_w = mass of water collected from separating calorimeter.

X = actual dryness fraction of steam in main pipe.

X_1 = apparent dryness fraction of steam measured by separating calorimeter assuming that the steam coming out of separating calorimeter is completely dry.

X_2 = Actual dryness fraction of steam entering into the throttling calorimeter.

	CHH. SHAHU COLLEGE OF ENGINEERING, AURANGABAD		LABORATORY MANUAL
	PRACTICAL EXPERIMENT INSTRUCTION SHEET		
	EXPERIMENT TITLE: Study of determination of dryness fraction of steam.		
DEPARTMENT:MECHANICAL ENGINEERING		LABORATORY :CSMSS/ENGG/MECH/TD LAB	
LABORATORY MANUAL NO.:CSMSS/ENGG/MECH/TD-03		YEAR:2016-17	
Class: Second Year	PART: I	SUBJECT: Thermodynamics- I	PAGE: 7 OF 8

The apparent dryness fraction is given by

$$X_1 = \frac{m_s}{m_s + m_w} \text{-----} 1$$

Amount of water carried by the steam before entering into the calorimeter =

$$\left(\frac{1 - X}{m_s + m_w} \right) \text{-----} 2$$

Amount of water separated in separating calorimeter =

$$\left(\frac{1 - X_1}{m_s + m_w} \right) \text{-----} 3$$

And the amount of water carried by the steam into the throttling calorimeter =

$$(1 - X_2)m_s \text{-----} 4$$

The mass of water in the steam given by the equation 2 must be equal to the quantities of water given by equations 3 & 4.

$$\left(\frac{1 - X}{m_s + m_w} \right) = \left(\frac{1 - X_1}{m_s + m_w} \right) + (1 - X_2)m_s$$

	CHH. SHAHU COLLEGE OF ENGINEERING, AURANGABAD		LABORATORY MANUAL
	PRACTICAL EXPERIMENT INSTRUCTION SHEET		
	EXPERIMENT TITLE: Study of determination of dryness fraction of steam.		
DEPARTMENT:MECHANICAL ENGINEERING		LABORATORY :CSMSS/ENGG/MECH/TD LAB	
LABORATORY MANUAL NO.:CSMSS/ENGG/MECH/TD-03		YEAR:2016-17	
Class: Second Year	PART: I	SUBJECT: Thermodynamics- I	PAGE: 8 OF 8

$$\left(\frac{1-X}{m_s + m_w} \right) = (1-X_1) + [1-X_2] \frac{m_s}{m_s + m_w}$$

But

$$X_1 = \frac{m_s}{m_s + m_w}$$

Substituting this value in above equation

$$1 - X = (1 - X_1) + (1 - X_2) \times X_1$$

$$X = X_1 \times X_2$$

Result :-

The dryness fraction of steam is _____.

	CHH. SHAHU COLLEGE OF ENGINEERING, AURANGABAD		LABORATORY MANUAL
	PRACTICAL EXPERIMENT INSTRUCTION SHEET		
	EXPERIMENT TITLE: Study and performance of flue gas analysis by using Orsat apparatus.		
DEPARTMENT:MECHANICAL ENGINEERING		LABORATORY :CSMSS/ENGG/MECH/TD LAB	
LABORATORY MANUAL NO.:CSMSS/ENGG/MECH/TD-04		YEAR:2016-17	
Class: Second Year	PART: I	SUBJECT: Thermodynamics- I	PAGE: 1 OF 6

Aim:-

Study and performance of flue gas analysis by using Orsat apparatus.

Introduction:-

The fuels available are in solid, liquid or gaseous form and mainly consist of carbon and hydrogen. The water vapour in the evaporated form is then integral part of the combustion products. The analysis of flue gases made taking water vapour into account is called the wet analysis. If the vapours are condensed and the condensate removed, then the flue gases will be dry and the analysis made thereof is referred to as dry analysis.

The volumetric analysis of dry products of combustion for a boiler or engine is done by means of Orsat apparatus. This is an apparatus used to analyze the flue gas containing CO_2 , CO and oxygen by volume. If the remainder of flue gas is nitrogen, it will also be known by difference.

Apparatus:-

Orsat Apparatus

Essentially the unit consists of three flasks containing chemicals to absorb different gases.

For example:

1. Flask 1 contains KOH (one part KOH + 2 parts of water by weight) and this absorbs CO_2 .
2. Flask 2 contains alkaline solution of pyrogallic acid (5gm pyrogallic acid in 15cc of water mixed with 120 gm KOH in 80cc of water) to absorb O_2 .
3. Flask 3 or sometimes 4 cuprous chloride (CuO dissolved in 20 times its weight of concentrated HCL acid till it becomes colorless) to absorb CO.

	CHH. SHAHU COLLEGE OF ENGINEERING, AURANGABAD		LABORATORY MANUAL
	PRACTICAL EXPERIMENT INSTRUCTION SHEET		
	EXPERIMENT TITLE: Study and performance of flue gas analysis by using Orsat apparatus.		
DEPARTMENT:MECHANICAL ENGINEERING		LABORATORY :CSMSS/ENGG/MECH/TD LAB	
LABORATORY MANUAL NO.:CSMSS/ENGG/MECH/TD-04		YEAR:2016-17	
Class: Second Year	PART: I	SUBJECT: Thermodynamics- I	PAGE: ² OF 6

Each flask is really made of two flasks joined together with glass tubing. Three such flasks are arranged in such a way that they form two rows called front row and back row. The top of each flask in a row is connected to a common header called front header and back header. The front header is further connected to eudiometer generally calibrated from 0 to 100cc. The eudiometer is surrounded by water jacket to keep its temperature constant. On the other side, the front header is provided with a 3-way valve which can connect it to flue gas supply or atmosphere or may remain closed. The back header is connected to rubber bladder.

The front part of each flask is provided with one way glass tap at the neck joining the front header. It is also provided with number of glass tubes inside it to accelerate the absorbing action of solution by providing wet surface. The back part of each flask has oil film which prevents the solution from any reaction with atmosphere. Eudiometer is connected by flexible rubber pipe to aspirator bottle whose position can be changed by lifting or lowering it. This consequently changes the level of liquid (pure water) contained in eudiometer. The aspirator bottle contains salt water which cannot dissolve any flue gases.

	CHH. SHAHU COLLEGE OF ENGINEERING, AURANGABAD		LABORATORY MANUAL
	PRACTICAL EXPERIMENT INSTRUCTION SHEET		
	EXPERIMENT TITLE: Study and performance of flue gas analysis by using Orsat apparatus.		
DEPARTMENT:MECHANICAL ENGINEERING		LABORATORY :CSMSS/ENGG/MECH/TD LAB	
LABORATORY MANUAL NO.:CSMSS/ENGG/MECH/TD-04		YEAR:2016-17	
Class: Second Year	PART: I	SUBJECT: Thermodynamics- I	PAGE: ³ OF 6

Figure Orsat Apparatus



PRACTICAL EXPERIMENT INSTRUCTION SHEET

EXPERIMENT TITLE: Study and performance of flue gas analysis by using Orsat apparatus.

DEPARTMENT:MECHANICAL ENGINEERING

LABORATORY :CSMSS/ENGG/MECH/TD LAB

LABORATORY MANUAL

NO.:CSMSS/ENGG/MECH/TD-04

YEAR:2016-17

Class: Second
Year

PART: I

SUBJECT: Thermodynamics- I

PAGE: 4 OF 6

ORSAT APPARATUS

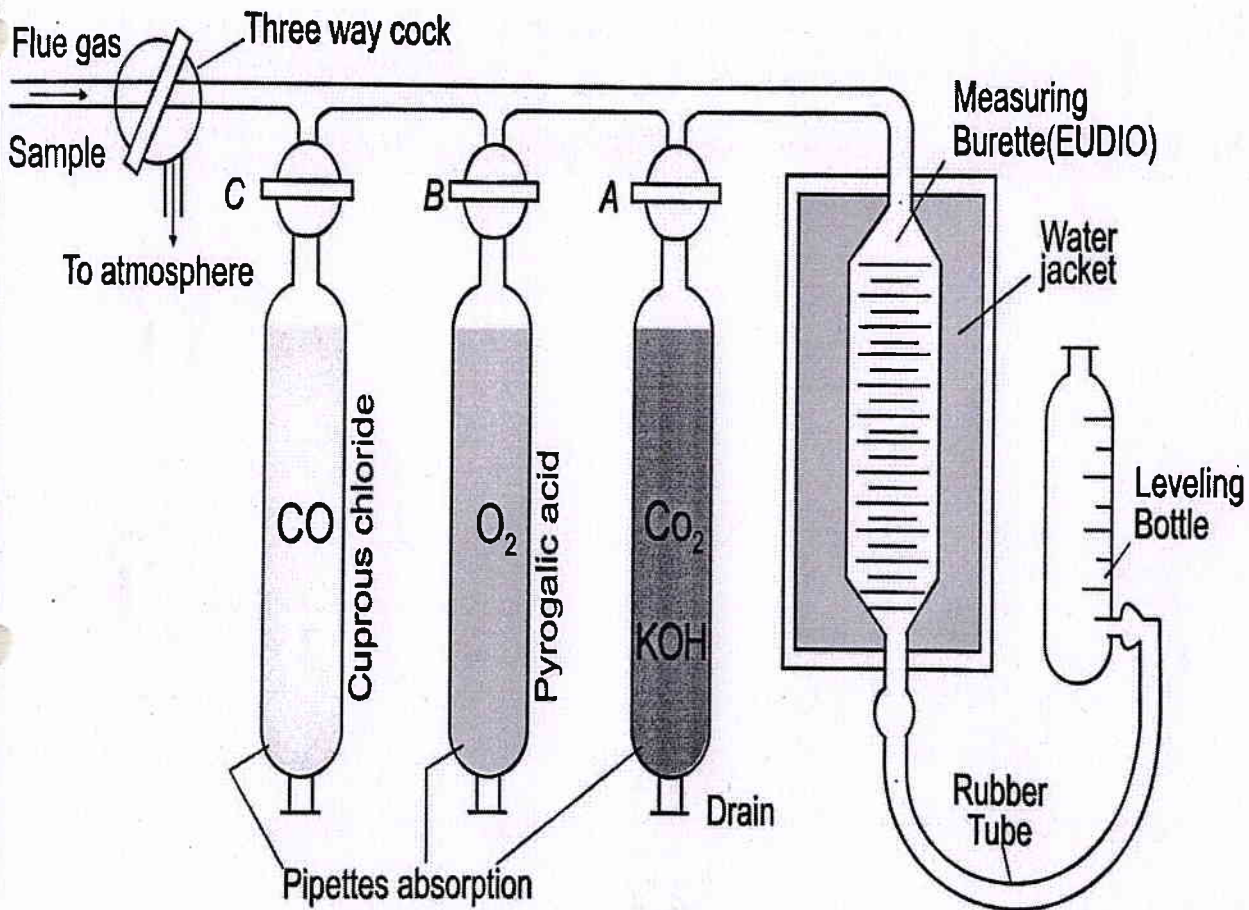

	CHH. SHAHU COLLEGE OF ENGINEERING, AURANGABAD		LABORATORY MANUAL
	PRACTICAL EXPERIMENT INSTRUCTION SHEET		
	EXPERIMENT TITLE: Study and performance of flue gas analysis by using Orsat apparatus.		
DEPARTMENT:MECHANICAL ENGINEERING		LABORATORY :CSMSS/ENGG/MECH/TD LAB	
LABORATORY MANUAL NO.:CSMSS/ENGG/MECH/TD-04		YEAR:2016-17	
Class: Second Year	PART: I	SUBJECT: Thermodynamics- I	PAGE: 5 OF 6

Operation:-

Step 1:

1. The whole apparatus is thoroughly cleaned, stoppers greased and then tested for air tightness.
2. The absorption flasks are filled with their respective solutions to level just below their rubber connections and their stop cocks A,B and C are then closed.
3. The jacket and aspirator bottle are filled with water.
4. The 3-way cock is opened to atmosphere and the aspirator bottle is raised up to expel any gas or air in the eudiometer or header.
5. The 3-way valve is now closed and the aspirator bottle is brought down so as to read zero on eudiometer scale.

Step 2:

1. The 3-way cock is now connected to flue gas supply and the aspirator bottle is lowered to draw in the gas.
2. The gas mixes with the air that may be present in the apparatus.
3. Accordingly the 3-way cock is opened to atmosphere and the gas expelled by raising the aspirator bottle.
4. The process of sucking and exhausting the gas is repeated 3-4 times so as to expel the air from the apparatus.
5. Finally, volume is adjusted to 100cc.
6. The 3-way stop cock is then closed.

	CHH. SHAHU COLLEGE OF ENGINEERING, AURANGABAD		LABORATORY MANUAL
	PRACTICAL EXPERIMENT INSTRUCTION SHEET		
EXPERIMENT TITLE: Study and performance of flue gas analysis by using Orsat apparatus.			
DEPARTMENT:MECHANICAL ENGINEERING		LABORATORY :CSMSS/ENGG/MECH/TD LAB	
LABORATORY MANUAL NO.:CSMSS/ENGG/MECH/TD-04		YEAR:2016-17	
Class: Second Year	PART: I	SUBJECT: Thermodynamics- I	PAGE: 6 OF 6

Step 3:

1. The stopper A of flask 1 containing caustic potash solution is opened and the aspirator bottle is raised to push the gas in the flask.
2. The aspirator bottle is moved up and down several times to ensure that all the CO₂ has been absorbed by the chemical solution in flask 1.
3. The unabsorbed gas is then taken back to the eudiometer till the level of solution in flask 1 stands at the constant mark (original level) and then its stopper is closed.
4. The levels of water in the eudiometer and aspirator bottle are equalized and the volume of residual gas is noted.
5. The decrease in volume gives the volume of CO₂ in 100cc of the flue gas sample.

Step 4:

1. The procedure is repeated and the volumes of O₂ and CO are similarly determined by passing the remaining gas through alkaline pyrogallic acid flask and cuprous chloride flask respectively.
2. The gas remaining in the eudiometer after the absorption of CO₂, O₂ and CO is taken as nitrogen.
3. It is worthwhile to point out that the following order is necessary for the absorption of gases: CO₂ first, O₂ next and CO last. This is because the absorbent used for O₂, i.e., pyrogallic acid can also absorb some CO₂.
4. In that case, the percentage of oxygen detected would be reported more.
5. The apparatus is handy, easy to use and fairly accurate. In order to ensure that only dry gas is being analyzed, the flue gas may be passed through a U-tube containing calcium chloride or some other drying agent before it enters the setup.

	CHH. SHAHU COLLEGE OF ENGINEERING, AURANGABAD		LABORATORY MANUAL
	PRACTICAL EXPERIMENT INSTRUCTION SHEET		
	EXPERIMENT TITLE: Study and performance of flue gas analysis by using Orsat apparatus.		
DEPARTMENT:MECHANICAL ENGINEERING		LABORATORY :CSMSS/ENGG/MECH/TD LAB	
LABORATORY MANUAL NO.:CSMSS/ENGG/MECH/TD-04		YEAR:2016-17	
Class: Second Year	PART: I	SUBJECT: Thermodynamics- I	PAGE: 7 OF 6

Conclusion:-

Hence we studied the Orsat apparatus for analysis of flue gases.

	CHH. SHAHU COLLEGE OF ENGINEERING, AURANGABAD		LABORATORY MANUAL
	PRACTICAL EXPERIMENT INSTRUCTION SHEET		
EXPERIMENT TITLE: Study of Redwood's Viscometer and determination of viscosity of lubricants			
DEPARTMENT:MECHANICAL ENGINEERING		LABORATORY :CSMSS/ENGG/MECH/TD LAB	
LABORATORY MANUAL NO.:CSMSS/ENGG/MECH/TD-05		YEAR:2016-17	
Class: Second Year	PART: I	SUBJECT: Thermodynamics- I	PAGE: 1 OF 5

Aim:-

Study of Redwood's Viscometer and determination of viscosity of lubricants.

Apparatus:-

Redwood viscometer no.1 & no.2, stop watch, Kohlrausch flask, thermometer, filter paper.

Principle:-

Viscosity is the property of a fluid that determines its resistance to flow. It is an indicator of flow ability of a lubricating oil, the lowest the viscosity, greater the flow ability.

Absolute Viscosity may be defined as "the tangential force per unit area which is required to maintain a unit velocity gradient between two parallel layers. It is denoted by η (eta). Its unit in CGS system is poise.

Viscosity index Viscosity generally decreases with increase in temperature. The maintenance of viscosity over the range of temperature is called the viscosity index (V.I).

A relatively small change in viscosity with temperature is indicated by high viscosity index whereas low viscosity index shows relatively large change in viscosity with temperature.

Effect of temperature on viscosity:

Viscosity of lubricating oil is inversely proportional to the temperature i.e with increase of temperature, viscosity decreases. This is due to the decrease in molecular interaction.

At higher temperature, oil must have sufficient viscosity to carry loads. Hence heavier oils are used at higher temperature. Similarly, light oils are used at low ambient temperature.

	CHH. SHAHU COLLEGE OF ENGINEERING, AURANGABAD		LABORATORY MANUAL
	PRACTICAL EXPERIMENT INSTRUCTION SHEET		
	EXPERIMENT TITLE: Study of Redwood's Viscometer and determination of viscosity of lubricants		
DEPARTMENT:MECHANICAL ENGINEERING		LABORATORY :CSMSS/ENGG/MECH/TD LAB	
LABORATORY MANUAL NO.:CSMSS/ENGG/MECH/TD-05		YEAR:2016-17	
Class: Second Year	PART: I	SUBJECT: Thermodynamics- I	PAGE: ² OF 5

Effect of pressure on viscosity

Lubricating oils are subjected to extreme pressures at the interphase between gears and rolling element. At such high pressures , viscosity of lubricating oil increases considerably.

Viscosity helps in selecting good lubricant oil.

<i>Light Oils</i>	<i>Heavy Oils</i>
Having low density	High density
Easy flow ability	Low flow ability
Used for: High speed, low pressure & low temperature	Used for: Low speed, high pressure & high temperature

Significance of viscosity measurement

Viscosity is the property of lubricating oil that determine its ability to lubricate and through its film strength, viscosity values are used.

1. In evaluating load carrying capacity
2. In denoting the effect of temperature changes and for determining the presence of contaminants in used oil during service.
3. Absolute viscosity values are required for use in all bearings design calculations and other lubrication engineering technical design problems.

	CHH. SHAHU COLLEGE OF ENGINEERING, AURANGABAD		LABORATORY MANUAL
	PRACTICAL EXPERIMENT INSTRUCTION SHEET		
EXPERIMENT TITLE: Study of Redwood's Viscometer and determination of viscosity of lubricants			
DEPARTMENT:MECHANICAL ENGINEERING		LABORATORY :CSMSS/ENGG/MECH/TD LAB	
LABORATORY MANUAL NO.:CSMSS/ENGG/MECH/TD-05		YEAR:2016-17	
Class: Second Year	PART: I	SUBJECT: Thermodynamics- I	PAGE: 3 OF 5

Procedure:-

1. Select the appropriate viscometer, either redwood viscometer no.1 or no.2 depending up on the nature of lubricating oil.
2. Clean the viscometer metallic oil cup properly with the help of suitable solvent e.g. CCl₄, ether, petroleum spirit or benzene and dry it to remove any traces of solvent.
3. Clean the outer water bath of viscometer and fill the water bath with clean water for determining the viscosity at 90°C or below.
4. Place the valve rod on the gate jet to close it and pour the test oil into the metallic oil cup to the maximum level.
5. Place a clean dry kohlrusch flask immediately below and directly in line with discharge gate jet.
6. Insert a clean thermometer in the metallic oil cup.
7. Place the thermocouple in the water bath and make the connections as well as cover it with the lid.
8. Heat the water filled in the bath slowly with constant stirring. When the oil in the cup attains a desired temperature, stop the heating.
9. Lift the valve rod and start the stop watch. Oil from the gate jet flows into the flask.
10. Stop the watch when lower meniscus of the oil reaches the 50 ml mark on the neck of receiving flask.
11. Record the time taken for 50 ml of the oil to collect in the flask.
12. Repeat the experiment to get more readings.



PRACTICAL EXPERIMENT INSTRUCTION SHEET

EXPERIMENT TITLE: Study of Redwood's Viscometer and determination of viscosity of lubricants

DEPARTMENT:MECHANICAL ENGINEERING

LABORATORY :CSMSS/ENGG/MECH/TD LAB

LABORATORY MANUAL
NO.:CSMSS/ENGG/MECH/TD-05

YEAR:2016-17

Class: Second
Year

PART: I

SUBJECT: Thermodynamics- I

PAGE: 4 OF 5

Figure: Redwood Viscometer

REDWOOD VISCOMETER

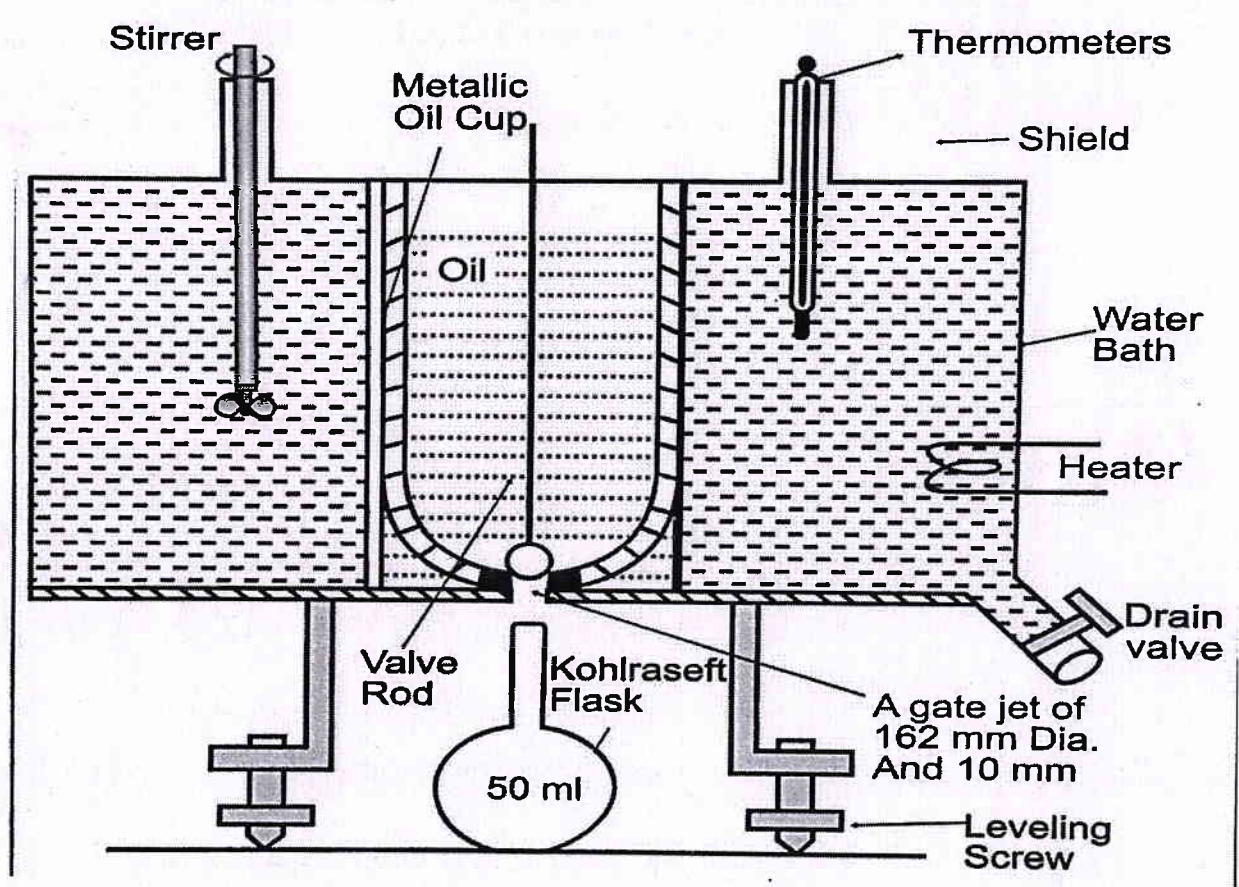

	CHH. SHAHU COLLEGE OF ENGINEERING, AURANGABAD		LABORATORY MANUAL
	PRACTICAL EXPERIMENT INSTRUCTION SHEET		
EXPERIMENT TITLE: Study of Redwood's Viscometer and determination of viscosity of lubricants			
DEPARTMENT:MECHANICAL ENGINEERING		LABORATORY :CSMSS/ENGG/MECH/TD LAB	
LABORATORY MANUAL NO.:CSMSS/ENGG/MECH/TD-05		YEAR:2016-17	
Class: Second Year	PART: I	SUBJECT: Thermodynamics- I	PAGE: ⁵ OF 5

Observation Table:

Sr No.	Type of oil	Temperature at which oil is being heated (°C)	Time required to fill up 50 ml flask	Viscosity

Result:-

The viscosity of given sample lubricating oil using Redwood viscometer at _____°C is _____.

	CHH. SHAHU COLLEGE OF ENGINEERING, AURANGABAD		LABORATORY MANUAL
	PRACTICAL EXPERIMENT INSTRUCTION SHEET		
	EXPERIMENT TITLE: Determination of cloud point and pour point of lubricants.		
DEPARTMENT:MECHANICAL ENGINEERING		LABORATORY :CSMSS/ENGG/MECH/TD LAB	
LABORATORY MANUAL NO.:CSMSS/ENGG/MECH/TD-06		YEAR:2016-17	
Class: Second Year	PART: I	SUBJECT: Thermodynamics- I	PAGE: ¹ OF 2

Aim: -

Determination of cloud point and pour point of lubricants.

Apparatus:-

1. Cooling bath with stand.
2. Glass jar with rubber gasket and cork.

Optional accessories required for test:-

1. Thermometer range below 0°C to -50°C.
2. Dry ice cubes.

Procedure:

1. Keep the bath in test position.
2. Fill up the dry cubes around the bath up to the neck of the bath.
3. Fill up sample oil in glass tube up to lower marked line and put rubber corks tightly. Place inside metal vessel.
4. Fix up thermometer in position.
5. The temperature will get down. Remove the jar from jacket quickly; inspect the oil for cloud point, when sample reveals cloudiness or haziness record the reading of the thermometer.
6. Close the jar and cool down again. Inspect the test jar at every 2°C interval, when the jar is tilted, hold the jar in horizontal position. If the oil shows no movement during 5 seconds record the reading. It is pour point of the sample oil.
7. Repeat the test, the result should not differ by more than 4°C.

	CHH. SHAHU COLLEGE OF ENGINEERING, AURANGABAD		LABORATORY MANUAL
	PRACTICAL EXPERIMENT INSTRUCTION SHEET		
	EXPERIMENT TITLE: Determination of cloud point and pour point of lubricants.		
DEPARTMENT:MECHANICAL ENGINEERING		LABORATORY :CSMSS/ENGG/MECH/TD LAB	
LABORATORY MANUAL NO.:CSMSS/ENGG/MECH/TD-06		YEAR:2016-17	
Class: Second Year	PART: I	SUBJECT: Thermodynamics- I	PAGE: ² OF 2

Calculation and reporting:-

Add 30°C to the temperature recorded above and corrected for thermometer errors if necessary and report the result the pour point for black oil, cylinder stock etc. Report both the upper and lower pour point.

Precision:-

Results of duplicate tests shall not differ by more than the following points

Repeatability- 6°C & Reproducibility- 6°C

Result:-

1. The cloud point for the given sample of _____ oil is _____.
2. The pour point for the given sample of _____ oil is _____.



CHH. SHAHU COLLEGE OF ENGINEERING, AURANGABAD

LABORATOR
Y
MANUAL

PRACTICAL EXPERIMENT INSTRUCTION SHEET

EXPERIMENT TITLE: Performance of multistage reciprocating air compressor

DEPARTMENT: MECHANICAL ENGINEERING

LABORATORY : CSMSS/ENGG/MECH/TD LAB

LABORATORY MANUAL

YEAR: 2015-16

NO.: CSMSS/ENGG/MECH/TD -05

Class: Second Year

PART: II

SUBJECT: Thermodynamics- II

PAGE: 1 OF 6

Aim: - Performance of multistage reciprocating air compressor

Introduction: -

The air compressor is two stage reciprocating type. The air is sucked from atmosphere and compressed in the first cylinder. The compressed air is then passes through the air cooler and then into the second stage cylinder, where the air is further compressed. The air further goes to the air reservoir through safety valve, which operates the electrical switch, when the pressure exceeds the limit. The test unit consists of a air chamber, containing an orifice plate, the manometer, compressor, an electrical dynamometer type induction motor

Specification:-

Particulars	Details
Diameter of HP cylinder	70 mm
Diameter of LP cylinder	85 mm
Length of stroke	64 mm
Maximum discharge pressure	12 Bar
Compressor speed	900 rpm
Motor speed	1440 rpm
HP of motor	3 HP
Orifice diameter	13 mm
Coefficient of discharge of orifice	0.65
Area of orifice	0.000132 m ²

Procedure: -

1. The outlet valve is closed.
2. The dynamometer is adjusted so that the circular balance reads zero, when the pointers at the motor pedestal coincides. This can be easily done by operating the hand wheel.
3. The manometer connections are checked. (the manometer may be filled with water up to the

	CHH. SHAHU COLLEGE OF ENGINEERING, AURANGABAD		LABORATORY Y MANUAL
	PRACTICAL EXPERIMENT INSTRUCTION SHEET		
	EXPERIMENT TITLE: Performance of multistage reciprocating air compressor		
DEPARTMENT:MECHANICAL ENGINEERING		LABORATORY :CSMSS/ENGG/MECH/TD LAB	
LABORATORY MANUAL NO.:CSMSS/ENGG/MECH/TD -05		YEAR:2015-16	
Class: Second Year	PART: II	SUBJECT: Thermodynamics- II	PAGE: 2 OF 6

half level).

4. The compressor is started and pressure is develops slowly.
5. At the particular pressure, the outlet valve is opened slowly and adjusted so that the pressure is maintained constant.
6. Take the all readings.

Observation table: -

Sr. No.	1 st stage discharge pressure (bar)	2 nd stage discharge pressure (bar)	Tank pressure/ delivery pressure (bar)	Air inlet temperature	Air inlet temperature to intercooler	Air outlet temperature to intercooler	Air outlet temperature of the HP cylinder	Manometer head in meter		Energy meter reading time required for 20 rev (Sec)
	P ₁	P ₂	P ₃	T ₁	T ₂	T ₃	T ₄	h ₁	h ₂	t
1										
2										
3										

Formulas used for volumetric efficiency: -

$$1. \text{ Volumetric efficiency} = \frac{V_1}{V_t} \times 100$$

Where,

V_1 = Actual volume of air compressor.

V_t = Theoretical volume of air.

2. Actual volume of air compressed at RTP (V_a)

	CHH. SHAHU COLLEGE OF ENGINEERING, AURANGABAD		LABORATOR Y MANUAL
	PRACTICAL EXPERIMENT INSTRUCTION SHEET		
	EXPERIMENT TITLE: Performance of multistage reciprocating air compressor		
DEPARTMENT: MECHANICAL ENGINEERING		LABORATORY : CSMSS/ENGG/MECH/TD LAB	
LABORATORY MANUAL NO.: CSMSS/ENGG/MECH/TD -05		YEAR: 2015-16	
Class: Second Year	PART: II	SUBJECT: Thermodynamics- II	PAGE: 3 OF 6

$$V_a = C_d \times A \times \sqrt{2gH} \text{ m}^3/\text{sec}$$

Where,

C_d = Coefficient of discharge of orifice

A = Area of orifice (m^2)

H = Air head causing flow

$$H = \frac{h \times \rho_{\text{water}}}{\rho_{\text{oil}} \times 100} \text{ meter}$$

$h = (h_1 - h_2)$ cm of water

3. Actual volume of air compressed at NTP (V_1):-

$$V_1 = \frac{V_A T_N}{T_R}$$

Where,

T_N = Normal temperature

T_R = Actual temperature

4. Theoretical volume of air :-

$$V_t = \frac{\pi}{4} \times D^2 \times L \times \frac{N_c}{60}$$

Where,

D = Diameter of HP cylinder

L = Length of stroke

N_c = RPM of compressor

Formula used for isothermal efficiency:-

1. Intake pressure (Absolute) P_1 (Bar): -

Intake pressure (Absolute) = Atmospheric pressure + Gauge pressure (Intake)

2. Intermediate pressure (Absolute) P_2 (Bar): -

Intermediate pressure (Absolute) = Atmospheric pressure + Gauge pressure (Intermediate)

3. Delivery pressure (Absolute) P_3 (Bar): -

	CHH. SHAHU COLLEGE OF ENGINEERING, AURANGABAD		LABORATORY Y MANUAL
	PRACTICAL EXPERIMENT INSTRUCTION SHEET		
EXPERIMENT TITLE: Performance of multistage reciprocating air compressor			
DEPARTMENT: MECHANICAL ENGINEERING		LABORATORY : CSMSS/ENGG/MECH/TD LAB	
LABORATORY MANUAL NO.: CSMSS/ENGG/MECH/TD -05		YEAR: 2015-16	
Class: Second Year	PART: II	SUBJECT: Thermodynamics- II	PAGE: 4 OF 6

Delivery pressure (Absolute) = Atmospheric pressure + Gauge pressure (delivery).

4. Compression ratio

a. First stage compression ratio, $r_1 = (P_2/P_1)$ ✓

b. Second stage compression ratio, $r_2 = (P_3/P_2)$ ✓

c. Overall compression ratio, $r = (P_3/P_1)$ ✓

5. Index of compression

Compression follows polytropic process,

$$P_1 V_1^n = P_2 V_2^n \quad \checkmark$$

$$\frac{T_2}{T_1} = \left(\frac{P_2}{P_1}\right)^{\frac{n-1}{n}} \quad \checkmark$$

$$n =$$

6. Work input to compressor,

$$W_{in} = \frac{3600 \times 10 \times 1000}{t \times EMC} \quad \checkmark$$

EMC = 800

7. Actual work done

Work done per cycle in compressing air in low pressure (LP) cylinder,

$$W_{LP} = \frac{n}{n-1} \left[P_1 V_1 \left(\left(\frac{P_2}{P_1} \right)^{\frac{n-1}{n}} - 1 \right) \right] \quad \checkmark$$

Work done per cycle in compressing air in high pressure (HP) cylinder,

$$W_{HP} = \frac{n}{n-1} \left[P_2 V_2 \left(\left(\frac{P_3}{P_2} \right)^{\frac{n-1}{n}} - 1 \right) \right] \quad \checkmark$$

Actual work done per cycle,

$$W = W_{LP} + W_{HP} \quad \checkmark$$

8. Indicated power (IP)

IP = Actual work done \times N / 60

$$IP = \frac{W \times N}{60}$$

9. Isothermal Work (W_{iso})

$$W_{iso} = P_1 V_1 \left(\log_e \left[\frac{P_3}{P_1} \right] \right)$$



CHH. SHAHU COLLEGE OF ENGINEERING, AURANGABAD

LABORATOR
Y
MANUAL

PRACTICAL EXPERIMENT INSTRUCTION SHEET

EXPERIMENT TITLE: Performance of multistage reciprocating air compressor

DEPARTMENT: MECHANICAL ENGINEERING

LABORATORY : CSMSS/ENGG/MECH/TD LAB

LABORATORY MANUAL
NO.: CSMSS/ENGG/MECH/TD -05

YEAR: 2015-16

Class: Second Year

PART: II

SUBJECT: Thermodynamics- II

PAGE: 5 OF 6

10. Isothermal Power = Isothermal work $\times N / 60$

$$\text{Isothermal power} = \frac{W_{iso} \times N}{60} \quad \checkmark$$

11. Isothermal efficiency (η_{iso})

$$\eta_{iso} = \text{Isothermal power} / \text{Indicated power} \quad \checkmark$$

12. FAD (Free Air Delivery)

$$FAD = \frac{\pi}{4} \times D^2 \times L \times \frac{N_c}{60} \quad \checkmark$$

	CHH. SHAHU COLLEGE OF ENGINEERING, AURANGABAD		LABORATORY Y MANUAL
	PRACTICAL EXPERIMENT INSTRUCTION SHEET		
	EXPERIMENT TITLE: Performance of multistage reciprocating air compressor		
DEPARTMENT:MECHANICAL ENGINEERING		LABORATORY :CSMSS/ENGG/MECH/TD LAB	
LABORATORY MANUAL NO.:CSMSS/ENGG/MECH/TD -05		YEAR:2015-16	
Class: Second Year	PART: II	SUBJECT: Thermodynamics- II	PAGE: 6 OF 6

Result: -

Sr. No.	Delivery pressure (Bar)	Input power (Watt)	Pressure ration	Isothermal Efficiency	Volumetric Efficiency	FAD

	CHH. SHAHU COLLEGE OF ENGINEERING, AURANGABAD		LABORATOR Y MANUAL
	PRACTICAL EXPERIMENT INSTRUCTION SHEET		
	EXPERIMENT TITLE: Study of cooling towers		
DEPARTMENT:MECHANICAL ENGINEERING		LABORATORY :CSMSS/ENGG/MECH/TD LAB	
LABORATORY MANUAL NO.:CSMSS/ENGG/MECH/TD -04		YEAR:2015-16	
Class: Second Year	PART: II	SUBJECT: Thermodynamics- II	PAGE: 1 OF 7

Aim: - Study of Cooling Towers.

Introduction:-

Power plants, air conditioning systems and some industries produce a large quantity of waste in the form of hot water. In the present scenario, in most of the places, the water supply is limited and thermal pollution is also serious concern. Therefore, the waste heat from water must be rejected for its reuse.

The cooling tower is direct contact type of heat exchanger. It is a semi enclosed, evaporative cooler. The water is sprayed through a certain height and an air current passes over it. Some water evaporates and heat of evaporation is extracted from falling water and surrounding air, thus both water and air cool.

Classification:-

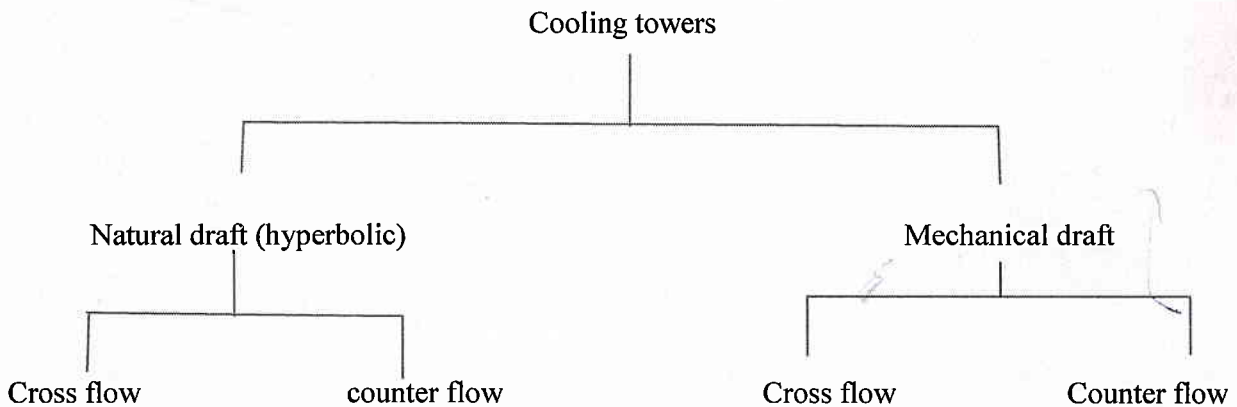

1. Natural draft cooling tower:

A natural draft cooling tower is tall and hyperbolic in construction. It looks like a large chimney and works as a ordinary chimney. The chimney effect is created by a hyperbolic profile of the tower. As air comes in contact of heated falling water, air is heated, becomes lighter and rises up in the tower. The cold and heavier outside air fills the vacant space creating an air flow. These towers do not require any external power to induce the air, but their construction cost is much more than

4-1

	CHH. SHAHU COLLEGE OF ENGINEERING, AURANGABAD		LABORATOR Y MANUAL
	PRACTICAL EXPERIMENT INSTRUCTION SHEET		
	EXPERIMENT TITLE: Study of cooling towers		
DEPARTMENT:MECHANICAL ENGINEERING		LABORATORY :CSMSS/ENGG/MECH/TD LAB	
LABORATORY MANUAL NO.:CSMSS/ENGG/MECH/TD -04		YEAR:2015-16	
Class: Second Year	PART: II	SUBJECT: Thermodynamics- II	PAGE: 2 OF 7

mechanical draft cooling towers. These are constructed from RCC and have base diameter ranging 75 to 100 m and height between 100m to 150m.

In the **cross flow** arrangement, the water is sprayed downward near the base of the tower on a fill material. Air is induced radially inward and flows in across the water.

In the **counter flow** arrangement as shown in the fig. Air enters through a peripheral section at the bottom of the tower and flows upward through a descending water spray made from a suitable height.

The heat exchanger section in cross and counter flow natural draft cooling towers occupies a small portion of the tower, while the remaining structure is used to promote the chimney effect. These towers are only suitable in desert regions, where moisture content in air is very low.

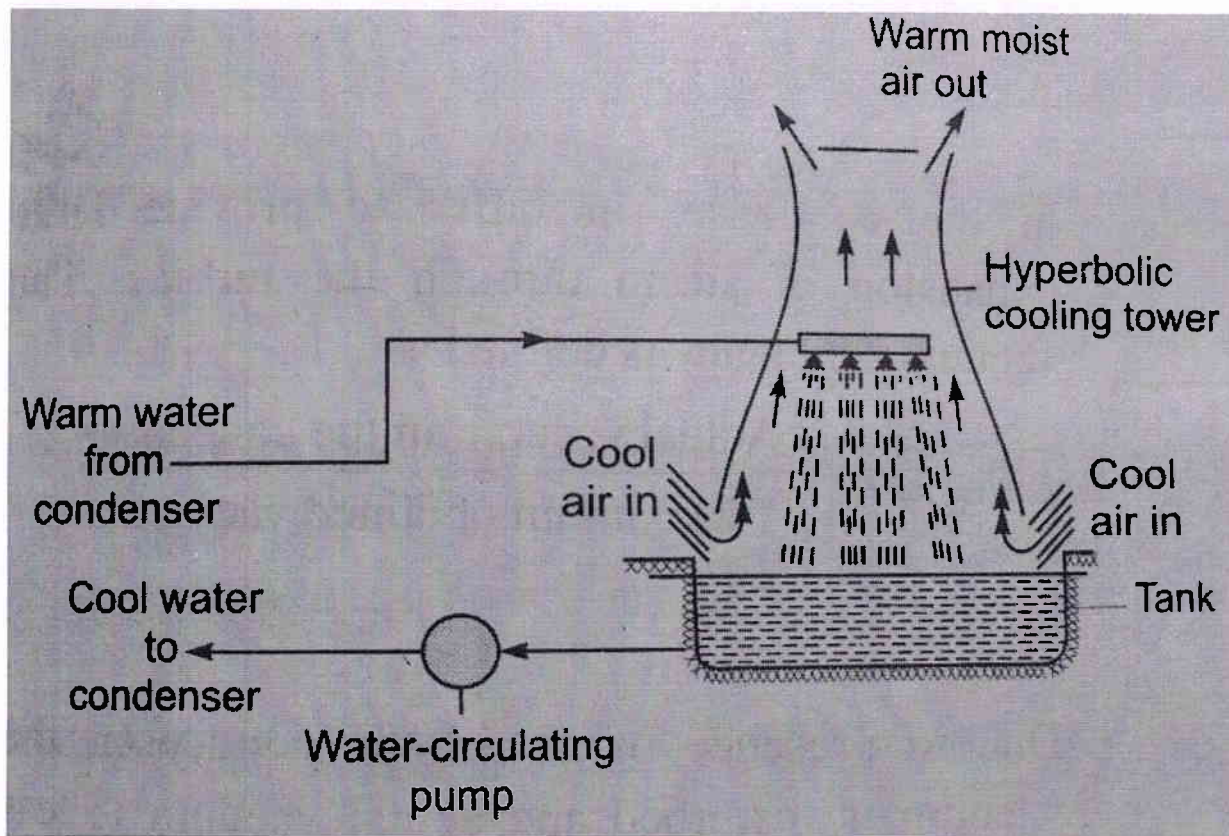



Fig – Natural draft cross flow cooling tower

	CHH. SHAHU COLLEGE OF ENGINEERING, AURANGABAD		LABORATOR Y MANUAL
	PRACTICAL EXPERIMENT INSTRUCTION SHEET		
EXPERIMENT TITLE: Study of cooling towers			
DEPARTMENT:MECHANICAL ENGINEERING		LABORATORY :CSMSS/ENGG/MECH/TD LAB	
LABORATORY MANUAL NO.:CSMSS/ENGG/MECH/TD -04		YEAR:2015-16	
Class: Second Year	PART: II	SUBJECT: Thermodynamics- II	PAGE: 3 OF 7

2. Mechanical or induced-draft cooling towers:-

These are induced draft cooling towers. These are compact in size with low height. The air movement through the tower is created by induced fans, located at the top of the tower.

An induced draft counter flow cooling tower is shown in fig. The warm water coming from the condenser is pumped to the top the tower and is sprayed into the air stream. The falling water passes through a series of baffles, thus the water breaks into fine droplets to promote evaporation. The atmospheric air is drawn in by an induced fan flowing upward, counter to the direction of the falling water droplets. As the two streams interact, a small fraction of water stream evaporates into moist air and cools the remaining falling water. The cooled water is collected at the bottom of the tower and is pumped backed to the condenser. The moist air is discharged from the top of the tower. Since some of the warm water is evaporated into the air stream, an equivalent amount of make-up water is added to the cycle.

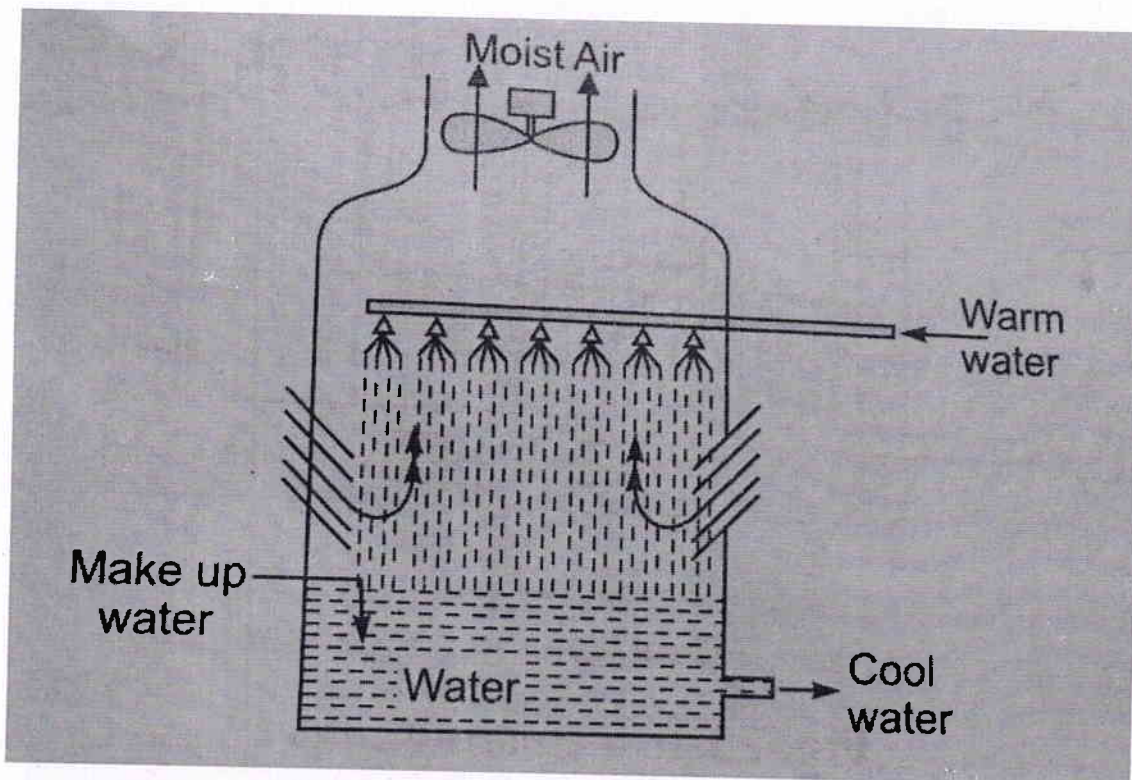



Fig – Induced draft cooling tower

	CHH. SHAHU COLLEGE OF ENGINEERING, AURANGABAD		LABORATORY Y MANUAL
	PRACTICAL EXPERIMENT INSTRUCTION SHEET		
	EXPERIMENT TITLE: Study of cooling towers		
DEPARTMENT:MECHANICAL ENGINEERING		LABORATORY :CSMSS/ENGG/MECH/TD LAB	
LABORATORY MANUAL NO.:CSMSS/ENGG/MECH/TD -04		YEAR:2015-16	
Class: Second Year	PART: II	SUBJECT: Thermodynamics- II	PAGE: 4 OF 7

Apparatus:-

1. It consists of packed bed cooling tower with a blower fan to create a draft.
2. A heater tank to heat the water, circulation pump to circulate the water of cooling tower from inlet to outlet pipe.
3. The panel consists of the pressure gauge and rota-meter for flow measurement, an On-Off switch and temperature indicator to show temperature at various point.
4. Water from hot water tank is collected with the help of pump in cooling tower and it discharged out without recirculation.

Specification of cooling tower:-

Sr. No.	Part Name	Specification
1	Type	FRP induced draft counter flow square shape
2	No. of cell	Single cell
3	Quantity	1 set
4	Dimensions (L X W)	900 mm x 900 mm
5	Height	2700 mm
6	Fan diameter	700mm/4 blades
7	Static pressure	107 pa.
8	Air quantity	2.31 m ³ /sec

4-4

	CHH. SHAHU COLLEGE OF ENGINEERING, AURANGABAD		LABORATOR Y MANUAL
	PRACTICAL EXPERIMENT INSTRUCTION SHEET		
	EXPERIMENT TITLE: Study of cooling towers		
DEPARTMENT: MECHANICAL ENGINEERING		LABORATORY : CSMSS/ENGG/MECH/TD LAB	
LABORATORY MANUAL NO.: CSMSS/ENGG/MECH/TD -04		YEAR: 2015-16	
Class: Second Year	PART: II	SUBJECT: Thermodynamics- II	PAGE: 5 OF 7

Auxiliary Equipment

9	Fan type	Axial flow
10	Fan RPM	900 rpm
11	Electric motor	AC square cage vertical flanged mounted extended threaded shaft type induction motor with totally enclosed weather proof enclosure and IP-55 degree of protection and 'F' class insulation.
12	Motor rating	1 HP / 960 rpm / 415 V / 50 Hz / 3 phase

Experimental Procedure:-

1. Fill the hot water in the tank completely and start the heater to get the temperature around 51 °C to 60 °C which may be achieved around within 1 hr.
2. Stir the water at constant intervals to break the film formation as soon as we get desired temperature then put off the heater.
3. Fully open the bypass valve of the circulation pump.
4. Adjust the water flow as desired with the help of rota-meter and allow the water to enter in the cooling tower at the desired head.
5. Wait till steady state is achieved.
6. Note down the readings of various temperature such as T₁, T₂, T₃, T₄, T₅ and T₆ temperature at various points such as water inlet – outlet, hot water tank temperature and ambient air temperature.
7. The pressure gauge shows the maximum head of water supply to the pump.
8. Note down the temperature readings at various intervals by changing the flow rate.
9. Measure the dry bulb and wet bulb temperature readings to find the relative humidity.
10. Empty the tank by opening the drain valve as soon as experiment is completed.

4-5

	CHH. SHAHU COLLEGE OF ENGINEERING, AURANGABAD		LABORATORY Y MANUAL
	PRACTICAL EXPERIMENT INSTRUCTION SHEET		
	EXPERIMENT TITLE: Study of cooling towers		
DEPARTMENT: MECHANICAL ENGINEERING		LABORATORY : CSMSS/ENGG/MECH/TD LAB	
LABORATORY MANUAL NO.: CSMSS/ENGG/MECH/TD -04		YEAR: 2015-16	
Class: Second Year	PART: II	SUBJECT: Thermodynamics- II	PAGE: 6 OF 7

Experiment

- Water flow rate – variable
- Heater power – constant
- Blower – fully opened

Observation table:-

Sr. No.	Water flow rate (LPM)	Air inlet dry bulb (T1 °C)	(Tank) water inlet temp. (T2 °C)	Water outlet temp. (T5 °C)	Air outlet temp. (T6 °C)	Head pressure (P bar)
1						
2						
3						

Calculations:-

Readings for different flow rate:-

1. Water flow rate = _____ LPH.

1 LPH = 0.00028 Kg/s.

Therefore,

Water flow rate = _____ Kg/s.

2. Heater capacity = 1.5 Kw.

Cooling range $\Delta T = \text{water inlet } T5 - \text{water outlet } T6$

= _____ °C

= _____ °C

4-6



CHH. SHAHU COLLEGE OF ENGINEERING, AURANGABAD

LABORATOR
Y
MANUAL

PRACTICAL EXPERIMENT INSTRUCTION SHEET

EXPERIMENT TITLE: Study of cooling towers

DEPARTMENT:MECHANICAL ENGINEERING

LABORATORY :CSMSS/ENGG/MECH/TD LAB

LABORATORY MANUAL

NO.:CSMSS/ENGG/MECH/TD -04

YEAR:2015-16

Class: Second Year

PART: II

SUBJECT: Thermodynamics- II

PAGE: 7 OF 7

$$Q \text{ (heat load)} = m C_p \Delta T$$

where,

m= Mass of water flow rate,

C_p = specific heat of water at constant pressure,

C_p = KJ / kg °C (value of C_p is given in heat and mass transfer data book which is constant)

$$Q \text{ (heat load)} = \underline{\hspace{10em}} \text{ kw}$$
$$= \underline{\hspace{10em}} \text{ kw}$$

Result:-

Sr. No.	Water flow rate (LPH)	Heat load (Q) (kw)	Cooling range (°C)

	CHH. SHAHU COLLEGE OF ENGINEERING, AURANGABAD		LABORATORY MANUAL
	PRACTICAL EXPERIMENT INSTRUCTION SHEET		
	EXPERIMENT TITLE: Study of Condensers		
DEPARTMENT: MECHANICAL ENGINEERING		LABORATORY : CSMSS/ENGG/MECH/TD LAB	
LABORATORY MANUAL NO.: CSMSS/ENGG/MECH/TD -03		YEAR: 2015-16	
Class: Second Year	PART: II	SUBJECT: Thermodynamics- II	PAGE: 1 OF 12

Aim: - Study of condensers

Description:-

D) Function

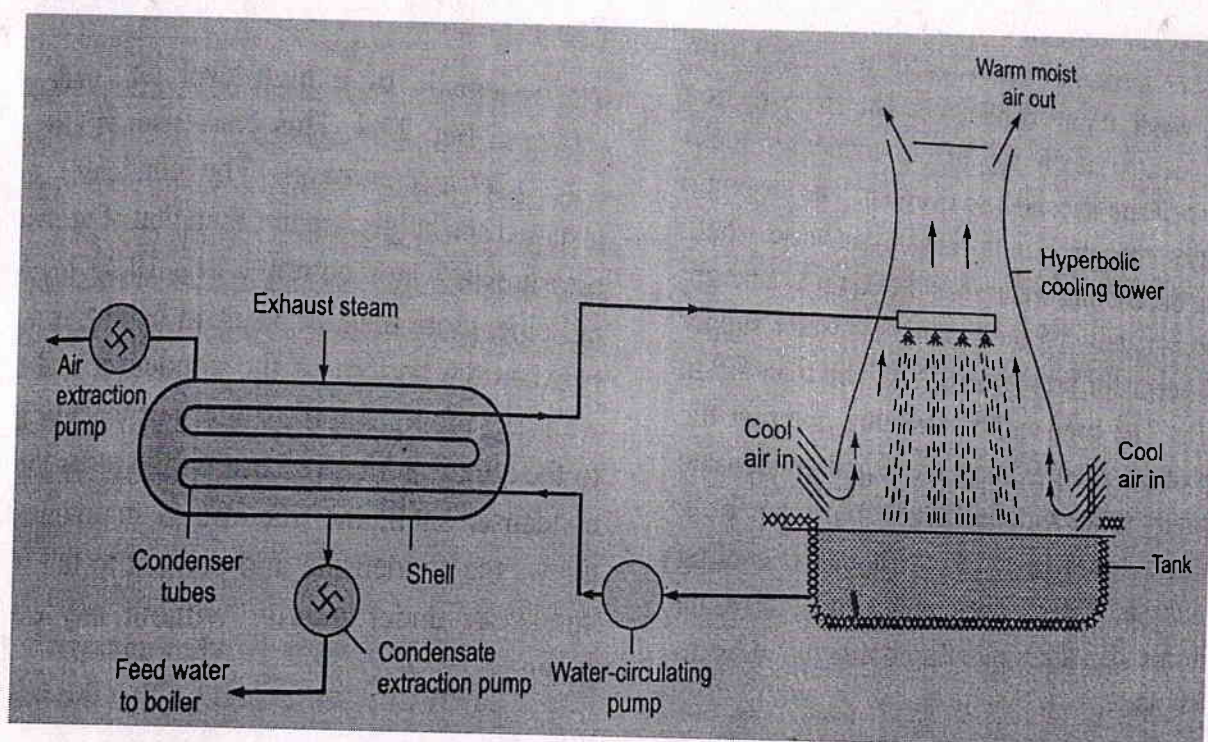



Fig.1:- Elements of a condensing plant

In a steam power plant, the condenser plays a very important role. The main function of a steam condenser are listed below

1. The condenser lowers the back pressure at the turbine exhaust. The steam expands through higher pressure ratio across the turbine. It results into
 - a) increase work done per cycle
 - b) improves thermal efficiency of the cycle
 - c) reduced steam consumption.

	CHH. SHAHU COLLEGE OF ENGINEERING, AURANGABAD		LABORATORY MANUAL
	PRACTICAL EXPERIMENT INSTRUCTION SHEET		
EXPERIMENT TITLE: Study of Condensers			
DEPARTMENT:MECHANICAL ENGINEERING		LABORATORY :CSMSS/ENGG/MECH/TD LAB	
LABORATORY MANUAL NO.:CSMSS/ENGG/MECH/TD -03		YEAR:2015-16	
Class: Second Year	PART: II	SUBJECT: Thermodynamics- II	PAGE: 2 OF 12

2. The condenser enables the recovery and recirculation of pure feed water into the plant. Thus,
 - a) the cost of water softening plant is reduced
 - b) it also saves the cost of fresh water to be supplied to the boiler.
3. The condenser enables the removal of air and non condensable gases from steam. Thus the heat transfer rate is improved and tube corrosion is reduced.

II) Types of condenser

There are mainly two types of condenser

1. Jet Condenser
2. Surface Condenser

1. Jet Condenser

In Jet Condenser the exhaust and cooling water come in direct contact and mix up together. Thus, the final temperature of the condensate and cooling water leaving the condenser is same. The cooling water is sprayed on the exhaust steam to cause the rapid condensation.

Jet condenser is very simple in design and cheaper than the surface condenser. It can be used when cooling water is cheaply and easily available. However, the condensate cannot be reused in the boiler, because it contains impurities like dust, oil, metal particles, etc. the jet condenser are also classified as

- A. Low level Jet Condenser - i) Counter flow type ii) parallel flow type.
- B. High level jet condenser
- C. Ejector jet condenser

	CHH. SHAHU COLLEGE OF ENGINEERING, AURANGABAD		LABORATORY MANUAL
	PRACTICAL EXPERIMENT INSTRUCTION SHEET		
	EXPERIMENT TITLE: Study of Condensers		
DEPARTMENT: MECHANICAL ENGINEERING		LABORATORY : CSMSS/ENGG/MECH/TD LAB	
LABORATORY MANUAL NO.: CSMSS/ENGG/MECH/TD -03		YEAR: 2015-16	
Class: Second Year	PART: II	SUBJECT: Thermodynamics- II	PAGE: 3 OF 12

A. Low level Counter flow Jet Condenser.

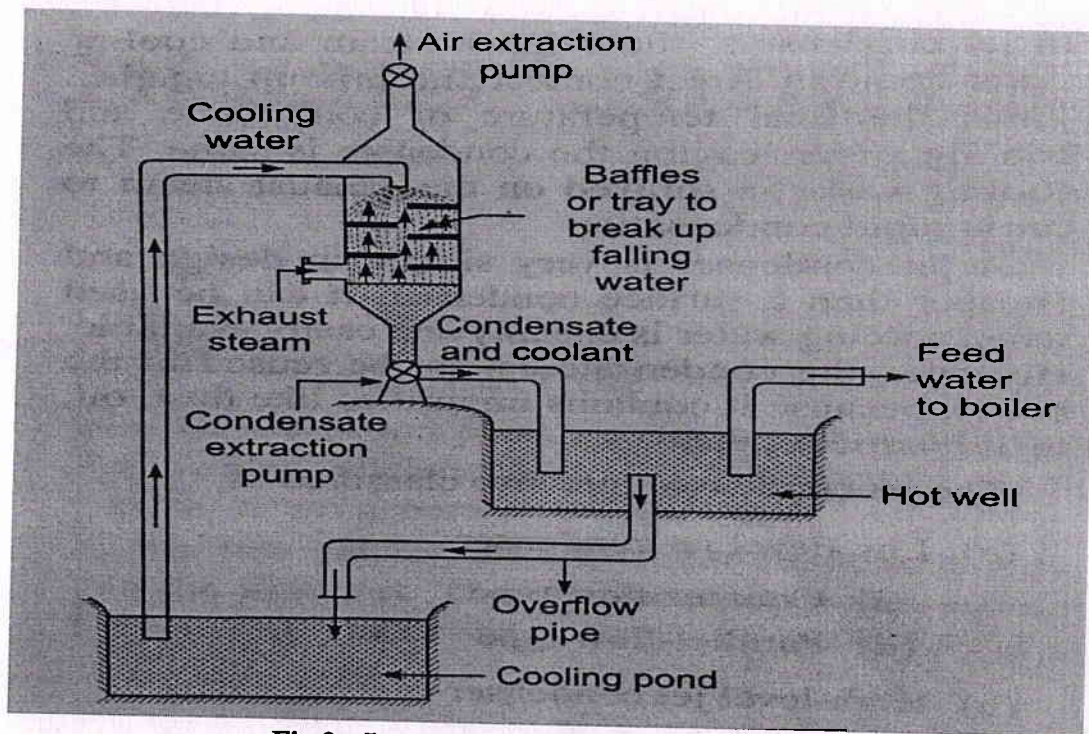



Fig 2:- Low level counter flow jet condenser

The schematic diagram of low level jet condenser is shown in figure 2. Exhaust steam is supplied from the bottom side of the condenser and it flows upward while the cooling water is supplied from the top of the condenser. The water flows downward through the series of baffles or trays. As steam comes in contact of the falling water, it gets condensed. The air extraction pump, located at the top of the condenser, sucks the air and any uncondensed vapour. The air pump maintains the enough vacuum in the condenser shell, causing the cooling water to lifted up to a height of 5.5 m a pump for water supply is only needed if it is to be lifted more than 5.5 m in height. The condenser extraction pump at the bottom of the shell extracts the liquid condensate and cooling water and discharges it to hot well, from where it may be fed to the boiler, if cooling water suits it. The excess amount of the condensate from there got well flows into the cooling pond by an overflow pipe.

	CHH. SHAHU COLLEGE OF ENGINEERING, AURANGABAD		LABORATORY MANUAL
	PRACTICAL EXPERIMENT INSTRUCTION SHEET		
	EXPERIMENT TITLE: Study of Condensers		
DEPARTMENT:MECHANICAL ENGINEERING		LABORATORY :CSMSS/ENGG/MECH/TD LAB	
LABORATORY MANUAL NO.:CSMSS/ENGG/MECH/TD -03		YEAR:2015-16	
Class: Second Year	PART: II	SUBJECT: Thermodynamics- II	PAGE: 4 OF 12

B. Low level Parallel flow Jet Condenser.

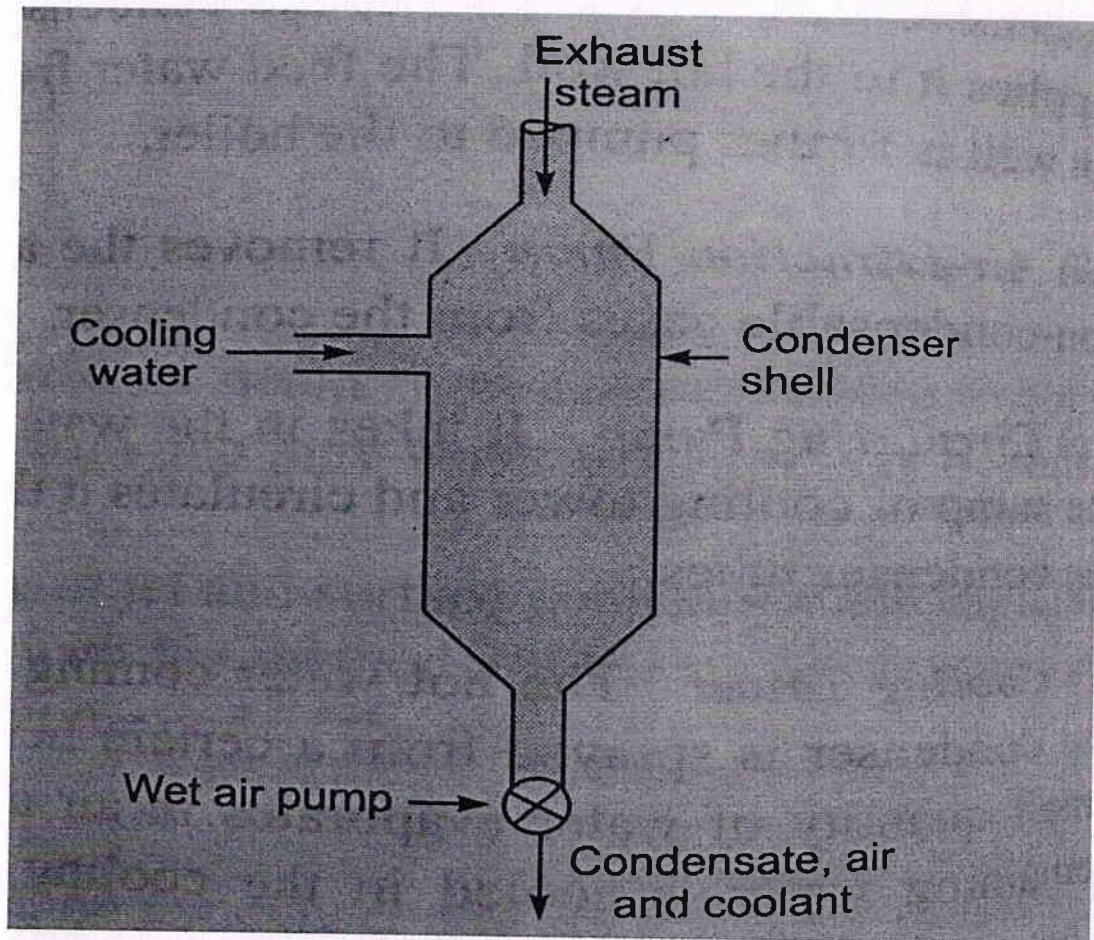

Fig. 3 :- Low level Parallel flow Jet Condenser

In this type of condenser, the exhaust and cooling water both flow in the same direction. The steam usually enters from the top of the condenser and the cooling water just below it from the side as shown in figure. Other arrangements are similar to counter flow jet condenser. The mixture of the condensate, coolant and air is extracted with the help of a wet air pump. These limit the vacuum created in the condenser up to 600 mm of Hg.



CHH. SHAHU COLLEGE OF ENGINEERING, AURANGABAD

LABORATORY
MANUAL

PRACTICAL EXPERIMENT INSTRUCTION SHEET

EXPERIMENT TITLE: Study of Condensers

DEPARTMENT: MECHANICAL ENGINEERING

LABORATORY : CSMSS/ENGG/MECH/TD LAB

LABORATORY MANUAL
NO.: CSMSS/ENGG/MECH/TD -03

YEAR: 2015-16

Class: Second Year

PART: II

SUBJECT: Thermodynamics- II

PAGE: 5 OF 12

C. High level jet condenser.

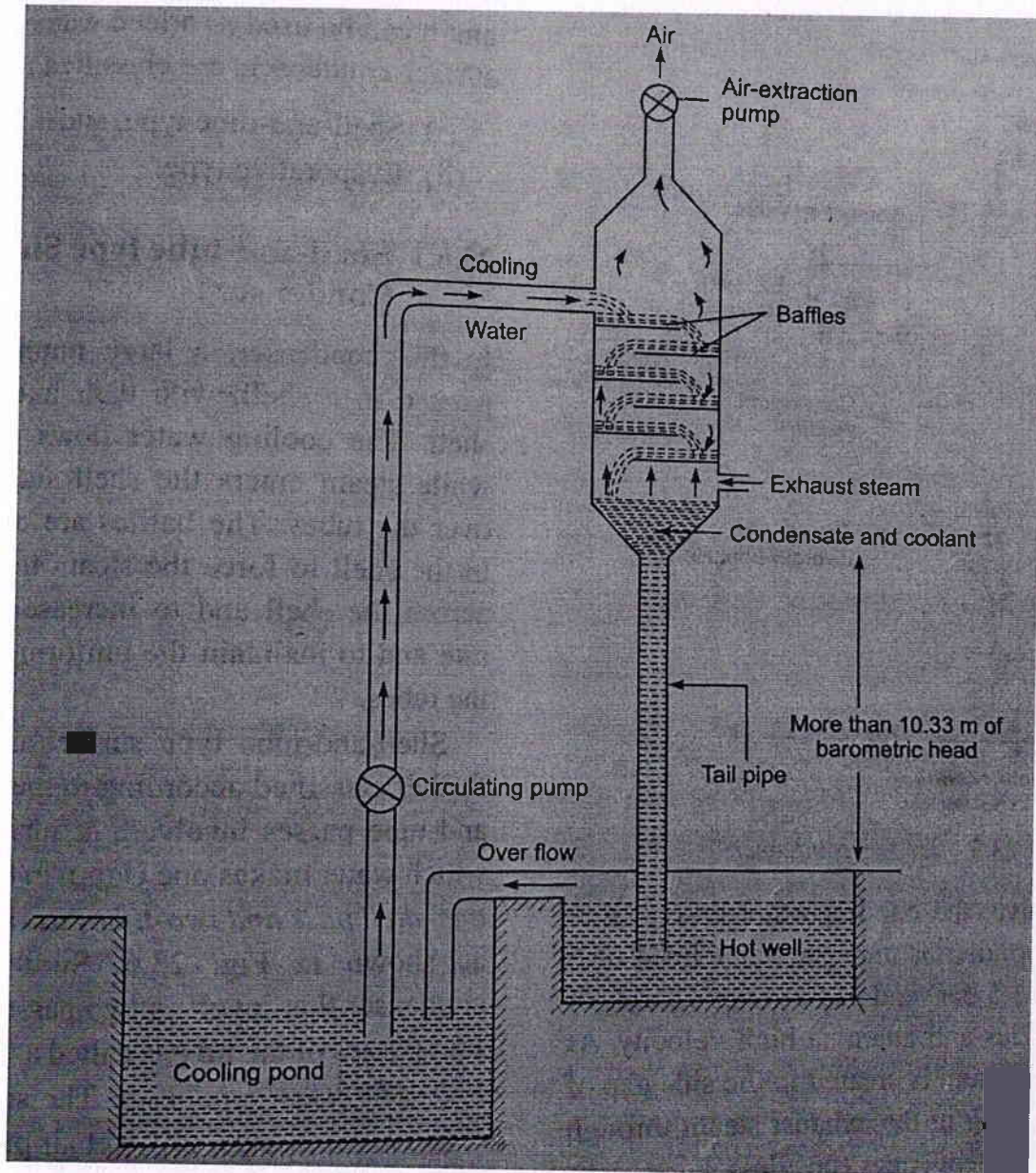



Fig. 4 :- High level jet condenser

	CHH. SHAHU COLLEGE OF ENGINEERING, AURANGABAD		LABORATORY MANUAL
	PRACTICAL EXPERIMENT INSTRUCTION SHEET		
	EXPERIMENT TITLE: Study of Condensers		
DEPARTMENT: MECHANICAL ENGINEERING		LABORATORY : CSMSS/ENGG/MECH/TD LAB	
LABORATORY MANUAL NO.: CSMSS/ENGG/MECH/TD -03		YEAR: 2015-16	
Class: Second Year	PART: II	SUBJECT: Thermodynamics- II	PAGE: 6 OF 12

The schematic of a high level jet condenser is as shown in figure. This condenser is also called as barometric condenser. The condenser shell is installed at height greater than that of atmospheric pressure in water column, i.e. 10.33 m a long tail pipe, more than 10.33 m height, is attached between the bottom of the condenser and the hot well. The pressure at the bottom of the pipe is equal to the atmospheric pressure, while at its top in the condenser shell, a vacuum is maintained. These allows the condensate and coolant to fall from the condenser under gravity without any extraction pump.

The cooling water is supplied by a water circulation pump. The water enters from the top of condenser and exhaust steam enters from the bottom of the condenser shell. The water stream is broken into fine spray droplet by baffles. The air released from the stream and water flows towards the top, where it is extracted by air extraction pump.

Advantages of the High level jet condenser

- It requires less floor space
- It requires only circulating pump of low capacity.
- The High level jet condensate falls due to the action of gravity.

Disadvantages of the High level jet condenser

- Due to high level of the condenser, long pipe lines are installed. Hence initial cost is high.
- It requires more head room with costly support structure
- It is not readily accessible for maintenance

	CHH. SHAHU COLLEGE OF ENGINEERING, AURANGABAD		LABORATORY MANUAL
	PRACTICAL EXPERIMENT INSTRUCTION SHEET		
	EXPERIMENT TITLE: Study of Condensers		
DEPARTMENT:MECHANICAL ENGINEERING		LABORATORY :CSMSS/ENGG/MECH/TD LAB	
LABORATORY MANUAL NO.:CSMSS/ENGG/MECH/TD -03		YEAR:2015-16	
Class: Second Year	PART: II	SUBJECT: Thermodynamics- II	PAGE: 7 OF 12

D. Ejector condenser

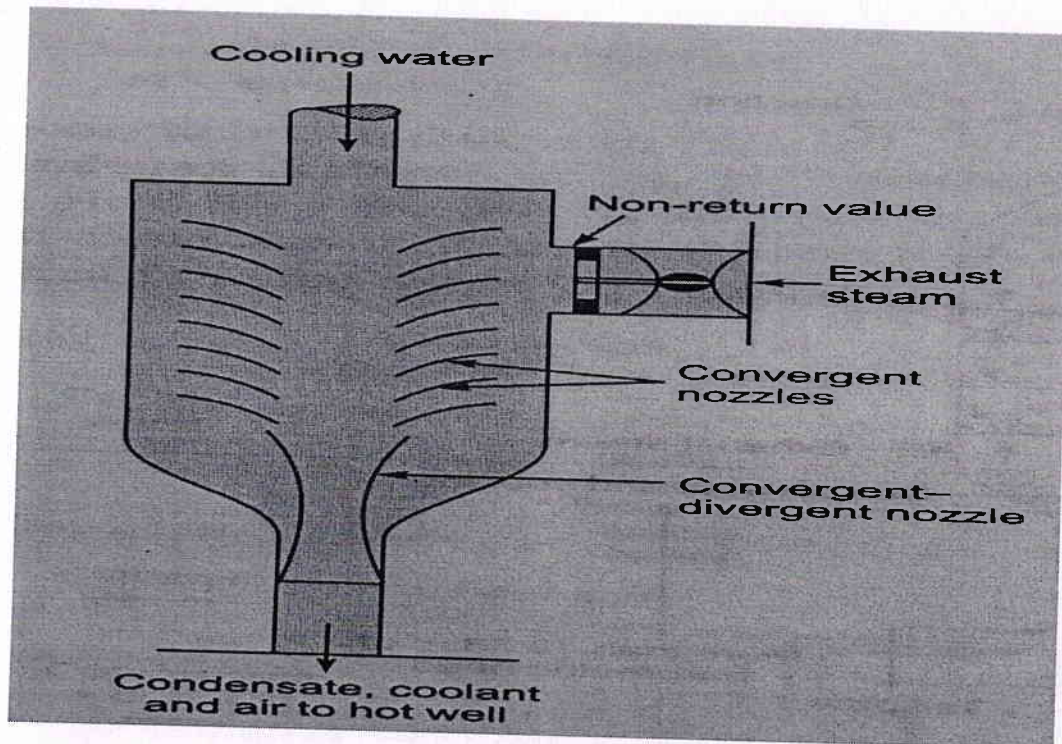



Fig. 5 :- Ejector condenser

In this condenser, the momentum of the flowing water is used to remove the mixture of condensate and coolant from the condenser without the use of any extraction pump. The schematic of the ejector condenser is shown in figure. The exhaust steam enter the condenser shell at side through a non- return valve, the cooling water enters from the top of condenser under a water head of 5 to 6 m and passes over a series of converging nozzle and attains a high velocity at the same time, vacuum is created in the side gap of the nozzle, drawing in the exhaust steam through the truncated divergent cones.

The mixing of steam and water caused condensation and hence the vacuum further increases in the side of the nozzles. In the central passage, a water and condensate gets momentum, which forces the mixture of condensate and water and air out of the shell.

	CHH. SHAHU COLLEGE OF ENGINEERING, AURANGABAD		LABORATORY MANUAL
	PRACTICAL EXPERIMENT INSTRUCTION SHEET		
	EXPERIMENT TITLE: Study of Condensers		
DEPARTMENT: MECHANICAL ENGINEERING		LABORATORY : CSMSS/ENGG/MECH/TD LAB	
LABORATORY MANUAL NO.: CSMSS/ENGG/MECH/TD -03		YEAR: 2015-16	
Class: Second Year	PART: II	SUBJECT: Thermodynamics- II	PAGE: 8 OF 12

2. Surface condenser

In the surface condenser the exhaust steam and cooling water does not come physical contact, rather they are shifted by a heat transfer wall. The exhaust steam passes over the outer surface of the tubes and the cooling water flows through the tubes. Since the cooling water does not mix with the condensing steam, the condensate remains pure and it can be used as feed water in the boiler. The surface condenser are classified into two groups

- A. Shell and tube type
- B. Evaporative type.

A. Shell and tube type

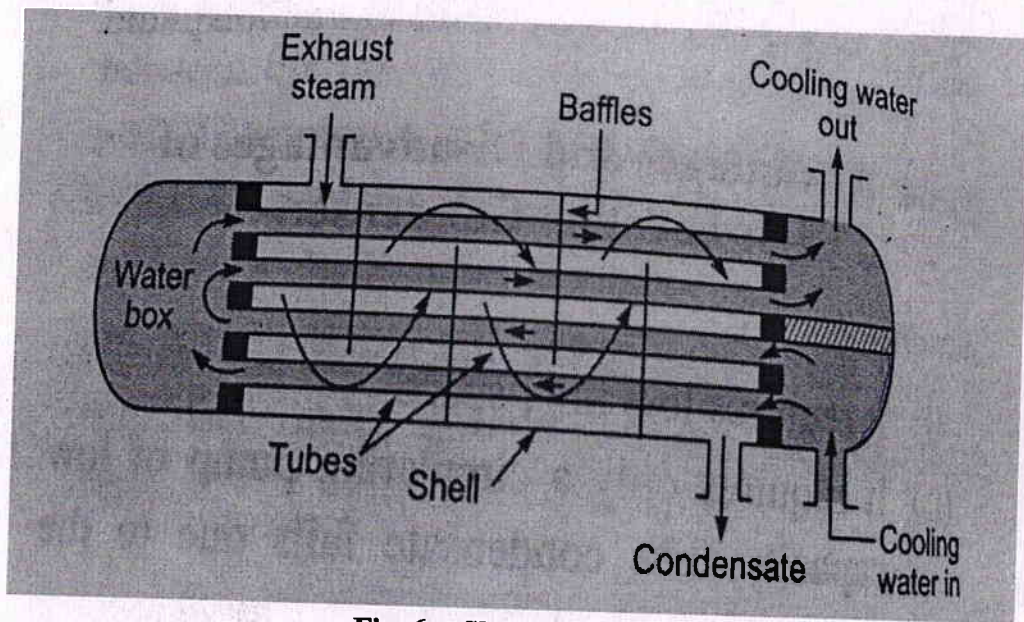



Fig. 6 :- Shell and tube type

In this condenser, a large number of tubes are packed in shell, with their axis parallel to the shell. The cooling water flows inside the tubes, while the steam enters the shell side and condenses over the tubes. The baffles are commonly placed in the shell to force the steam to

M4, Tom

1-1/2 [all des fcs]

07 -

	CHH. SHAHU COLLEGE OF ENGINEERING, AURANGABAD		LABORATORY MANUAL
	PRACTICAL EXPERIMENT INSTRUCTION SHEET		
	EXPERIMENT TITLE: Study of Condensers		
DEPARTMENT: MECHANICAL ENGINEERING		LABORATORY : CSMSS/ENGG/MECH/TD LAB	
LABORATORY MANUAL NO.: CSMSS/ENGG/MECH/TD -03		YEAR: 2015-16	
Class: Second Year	PART: II	SUBJECT: Thermodynamics- II	PAGE: 9 OF 12

flow along path across the shell and to increase the heat transfer rate and to maintain the uniform spacing between the tubes.

- a. Shell and tube type surface condenser can be classified according to the number of shell and tube passes involved. A surface condenser, in which water makes one U turn in the water box, is one shell pass and two tube pass surface condenser as shown in figure. Similarly the surface condenser that involves two passes in the shell and four passes in the tubes is called two shell pass and four tube pass condenser the surface condenser required to pumps i.e. wet air pump to remove air pump and condensate and water pump to circulate the cooling water under the pressure through the tubes these are mainly used in large power plants and chemical industries
 - b. The surface condenser are classified according to direction of steam flow
 - i. Down flow
 - ii. Central flow
 - iii. Inverted flow
- i. Down flow surface condenser

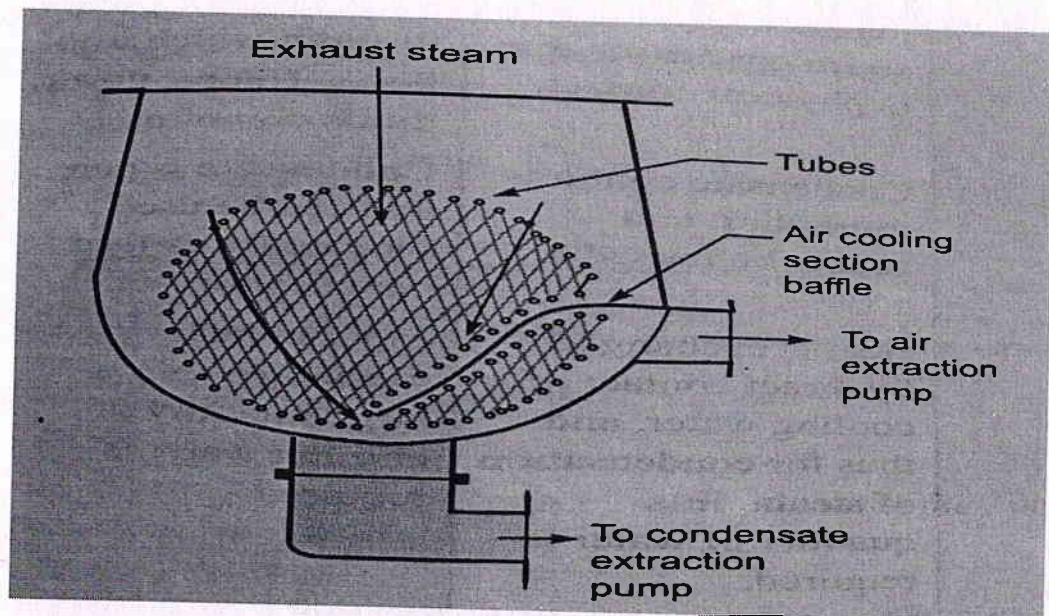



Fig. 7 :- Down flow surface condenser

	CHH. SHAHU COLLEGE OF ENGINEERING, AURANGABAD		LABORATORY MANUAL
	PRACTICAL EXPERIMENT INSTRUCTION SHEET		
	EXPERIMENT TITLE: Study of Condensers		
DEPARTMENT:MECHANICAL ENGINEERING		LABORATORY :CSMSS/ENGG/MECH/TD LAB	
LABORATORY MANUAL NO.:CSMSS/ENGG/MECH/TD -03		YEAR:2015-16	
Class: Second Year	PART: II	SUBJECT: Thermodynamics- II	PAGE: 10 OF 12

The sectional view of down flow surface condenser is shown in figure. The exhaust steam enters the top of the condenser shell and flows downward over the water tubes. The water tubes are double passed. The cold water flows in the lower side and then in the upper side in reverse direction. It enables the maximum heat transfer rate for a condenser. The extraction pump connected at the bottom of the condenser draws the condensate out of the condenser.

The air pump extracts the air and non condensable gases from condenser. The separated air under the baffles is cooled to maximum extent. Due to cooling of air, the specific volume is reduced therefore; the power consumption for operation for pump is reduced.

ii. Central flow surface condenser

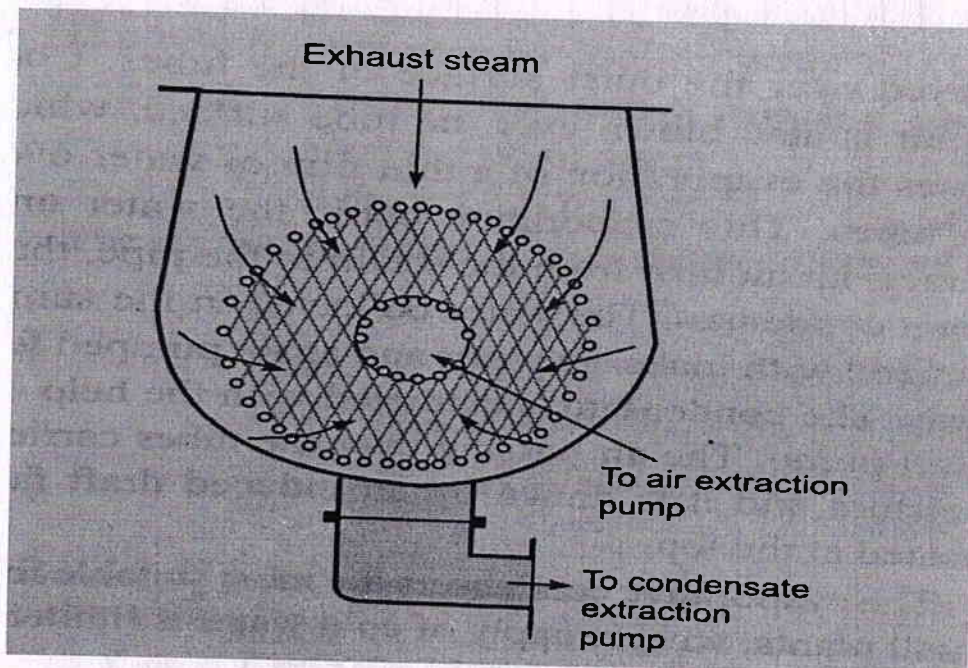



Fig. 8 :- Central flow surface condenser

The sectional view of central flow surface condenser is shown in figure. The suction pipe of air extraction pump is located at the center of the condenser tubes. The steam flows

	CHH. SHAHU COLLEGE OF ENGINEERING, AURANGABAD		LABORATORY MANUAL
	PRACTICAL EXPERIMENT INSTRUCTION SHEET		
	EXPERIMENT TITLE: Study of Condensers		
DEPARTMENT:MECHANICAL ENGINEERING		LABORATORY :CSMSS/ENGG/MECH/TD LAB	
LABORATORY MANUAL NO.:CSMSS/ENGG/MECH/TD -03		YEAR:2015-16	
Class: Second Year	PART: II	SUBJECT: Thermodynamics- II	PAGE: 11 OF 12

rapidly inwards. The condensate is collected at the bottom of the shell from where it is taken out by the condensate extraction pump. The steam gets access to entire periphery of tube the large surface area for heat transfer is available as compared to down flow condenser.

iii. Inverted flow surface condenser

The steam enters the bottom of the shell and air extraction pump is connected at the top. Steam flows upwards first and subsequently, return to the bottom of the condenser the condensate extraction pump is connected at the bottom of the shell to extract the condensate.

B. Evaporative condenser

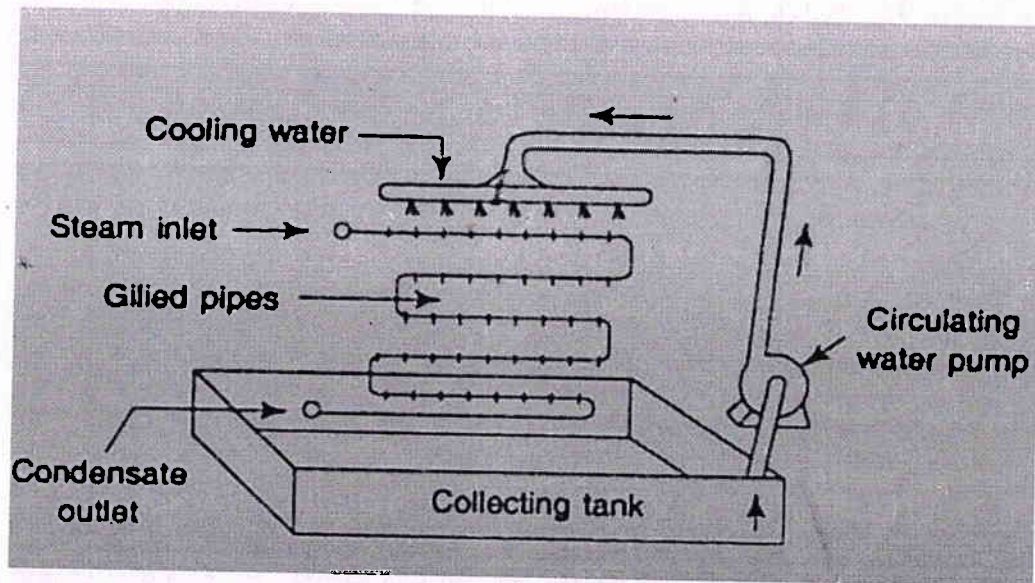



Fig. 9 :- Evaporative condenser

In this type of condenser, the evaporation of some cooling water provides cooling effect, thereby steam condenses. An evaporative condenser is as shown in figure. The steam to be condensed is passed through the fine tube the cooling water is sprayed over the outer surface of the tube. Cool dry air is also blown over the tube surface, which causes the evaporation of thin film of water over the tubes. This evaporation

	CHH. SHAHU COLLEGE OF ENGINEERING, AURANGABAD		LABORATORY MANUAL
	PRACTICAL EXPERIMENT INSTRUCTION SHEET		
EXPERIMENT TITLE: Study of Condensers			
DEPARTMENT: MECHANICAL ENGINEERING		LABORATORY : CSMSS/ENGG/MECH/TD LAB	
LABORATORY MANUAL NO.: CSMSS/ENGG/MECH/TD -03		YEAR: 2015-16	
Class: Second Year	PART: II	SUBJECT: Thermodynamics- II	PAGE: 12 OF 12

cools the water and extracts latent heat from the steam in the pipe, thus steam condenses. The water collected in the sump is mixed with makeup water and again pumped for spray. The condensate is extracted with the help of wet pump the air passing over the tubes carries moisture and it is drawn by a induced draft fan located at the top.

The evaporative condenser is most available for small plant, where supply of cold water is limited. These are most popular with refrigeration condensing units and for chemical equipment..

Advantages

1. The surface condenser lowers the back pressure of steam at the turbine exit, and thus allows the expansion of steam through a higher pressure ration.
2. It has vacuum efficiency, and is thus suitable for large power plant.
3. It used pure condensate which can be re-circulated as feed water to the boiler.
4. Since the condensate is reused, it saves the cost of fresh water to be circulated and the cost of its chemical treatment.
5. It requires low power input for air extraction pump.
6. Since the cooling water is indirect contact of steam, low quality cooling water can be used in the condenser.
7. The cooling of condensate can be controlled by regulating the flow of cooling water.

Disadvantages

1. Indirect cooling takes place in the condenser and thus large cooling water is required
2. Construction is complicated, requires higher installation cost
3. It requires costly maintenance and skilled workers
4. It requires large floor area

Conclusion: - We will be able to identify and distinguish the different types of condensers.

	CHH. SHAHU COLLEGE OF ENGINEERING, AURANGABAD		LABORATORY MANUAL
	PRACTICAL EXPERIMENT INSTRUCTION SHEET		
	EXPERIMENT TITLE: Study of Boilers		
DEPARTMENT: MECHANICAL ENGINEERING		LABORATORY : CSMSS/ENGG/MECH/TD LAB	
LABORATORY MANUAL NO.: CSMSS/ENGG/MECH/TD		YEAR: 2024-25	
Class: Third Year	PART: II	SUBJECT: Applied Thermodynamics	PAGE: 1 OF 8

Aim: - Study of Boilers

Introduction:

A steam generator or boiler is a closed vessel, generally made of steel, in which water is heated by some source of heat produced by the combustion of fuel (coal) and ultimately generates steam. The steam produced may be supplied at low pressure for industrial process work in cotton mills, sugar industries etc., and for producing hot water which can be used for heating installations at much low pressure.

Steam: Steam is the gas formed when water passes from the liquid to the gaseous state. At the molecular level, this is when H₂O molecules manage to break free from the bonds (i.e. hydrogen bonds) keeping them together. In liquid water, H₂O molecules are constantly being joined together and separated. As the water molecules are heated, however, the bonds connecting the molecules start breaking more rapidly than they can form. Eventually, when enough heat is supplied, some molecules will break free. These 'free' molecules form the transparent gas we know as steam or more specifically dry steam.

Classification of Boiler

1. Water tube boiler
2. Fire tube boiler

Water-tube boiler: It is a boiler in which the water is present inside the tubes and the hot flue gases surround the tubes. Since the water is present inside the tubes hence these boilers are called water tube boilers.

The various water tube boilers are the following:

- 1) Babcock & Wilcox boiler
- 2) Sterling boiler
- 3) Lamont boiler

	CHH. SHAHU COLLEGE OF ENGINEERING, AURANGABAD		LABORATORY MANUAL
	PRACTICAL EXPERIMENT INSTRUCTION SHEET		
EXPERIMENT TITLE: Study of Boilers			
DEPARTMENT: MECHANICAL ENGINEERING		LABORATORY : CSMSS/ENGG/MECH/TD LAB	
LABORATORY MANUAL NO.: CSMSS/ENGG/MECH/TD		YEAR: 2024-25	
Class: Third Year	PART: II	SUBJECT: Applied Thermodynamics	PAGE: 2 OF 8

4) Loeffler boiler

5) Benson boiler

6) Velox boiler

Fire-tube boiler: It is a boiler in which the hot flue gases are present inside the tubes and the water surrounds these tubes. As fire is present inside the tubes, hence it is called a fire tube boiler.

The various fire tube boilers are the following:

1) Simple vertical boiler

2) Cochran boiler

3) Lancashire boiler

4) Locomotive boiler

5) Scotch marine

Cornish boiler Specifications of simple vertical boiler: It is the simplest form of a vertical boiler, and produces steam at low pressure and in small quantities. In this boiler, the heating surface is composed of multiple small fire tubes, which are arranged vertically. The steam generating rate of this type of boiler is normally 2500 kg per hour with a pressure of about 7.4 bar to 9.9 bar. The construction of this type of boiler.



CHH. SHAHU COLLEGE OF ENGINEERING, AURANGABAD

LABORATORY
MANUAL

PRACTICAL EXPERIMENT INSTRUCTION SHEET

EXPERIMENT TITLE: Study of Boilers

DEPARTMENT: MECHANICAL ENGINEERING

LABORATORY : CSMSS/ENGG/MECH/TD LAB

LABORATORY MANUAL
NO.: CSMSS/ENGG/MECH/TD

YEAR: 2024-25

Class: Third Year

PART: II

SUBJECT: Applied Thermodynamics

PAGE: 3 OF 8

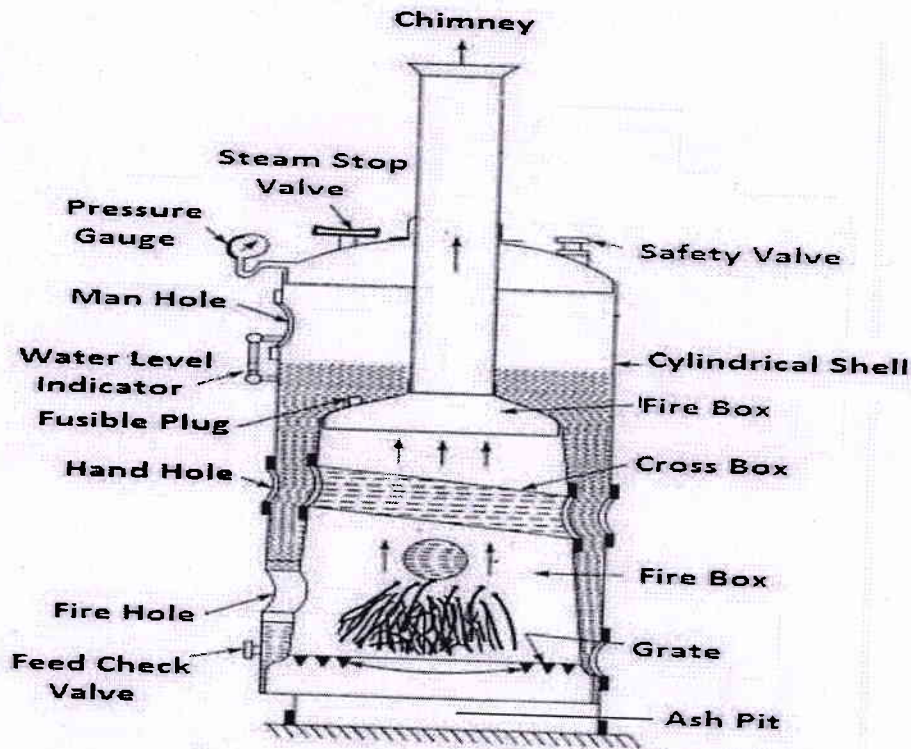

Vertical Boiler

Construction of a simple vertical boiler A brief description of a simple vertical boiler is as: Cylindrical shell: The shell is in a vertical position and attached to the bottom of the firebox. The greater portion of the shell is filled with water which also surrounds the firebox, whereas the remaining portion is the steam space. The shell can be about 1.25 meters in diameter and 2 meters in height. Chimney: The chimney is located on the top portion of the boiler shell. It is employed to stack exhaust gases into the environment. Manhole: The manhole is provided at the top of the boiler shell, and is used for repair and maintenance from the inside. Further, it is used for cleaning the inner part of the boiler shell and the outer part of the combustion chamber as well as the chimney, etc. The manhole is mostly oval in shape (400×300 mm) in size, whereas the opening of this is closed by a cover known as a manhole door. Hand-hole: It is provided in the boiler shell opposite the ends of each cross tube for cleaning the cross tube. Cross tubes: One or more cross

	CHH. SHAHU COLLEGE OF ENGINEERING, AURANGABAD		LABORATORY MANUAL
	PRACTICAL EXPERIMENT INSTRUCTION SHEET		
EXPERIMENT TITLE: Study of Boilers			
DEPARTMENT:MECHANICAL ENGINEERING		LABORATORY :CSMSS/ENGG/MECH/TD LAB	
LABORATORY MANUAL NO.:CSMSS/ENGG/MECH/TD		YEAR:2024-25	
Class: Third Year	PART: II	SUBJECT: Applied Thermodynamics	PAGE: 4 OF 8

tubes are either flanged or fastened to the firebox in order to enhance the heating surface and also improve water circulation. Combustion chamber: The furnace or firebox is an important part of all types of boilers, where the combustion of fuel takes place in order to generate heat. It is also known as the heating surface for a boiler. The heat that is generated is transferred to the water inside the boiler and produced steam. A refractory brick is used inside the combustion chamber in order to prevent heat losses, and also increased the efficiency of the boiler. Fire Box: It is a type of box in which the burning of solid fuel (mostly coal) takes place inside the boiler. A grate is usually made of cast iron bars which are spaced aside so that the air can pass through them. It is a platform, in the combustion chamber, upon which the fuel (coal) is burnt. Ash pit: The main function of the ash pit is to collect ash after burning the fuel which is coal. Working of simple vertical boiler when fuel (coal) is placed in the firebox and burns then hot flue gas is generated. Then these hot flue gases pass through the fire tube (inside the tubes) and heat the surrounding water. When the water is heated then it is converted into saturated steam and stored in the steam chamber. Further the saturated steam passes from the steam chamber to the super heater in order to burn the water vapour, present in the steam and become superheated steam goes to the steam turbine to produce the electric power. Furthermore, waste flue gases produced during the burning of fuel exit from the furnace (firebox) to the chimney. It provided all required mountings as:

- Pressure gauge
- Water level indicator
- Safety valve
- Fusible plug
- Blow off cock
- Steam stop valve

The following are the advantages of a simple vertical boiler:

- The initial cost is low because of fewer parts

	CHH. SHAHU COLLEGE OF ENGINEERING, AURANGABAD		LABORATORY MANUAL
	PRACTICAL EXPERIMENT INSTRUCTION SHEET		
EXPERIMENT TITLE: Study of Boilers			
DEPARTMENT: MECHANICAL ENGINEERING		LABORATORY : CSMSS/ENGG/MECH/TD LAB	
LABORATORY MANUAL NO.: CSMSS/ENGG/MECH/TD		YEAR: 2024-25	
Class: Third Year	PART: II	SUBJECT: Applied Thermodynamics	PAGE: 5 OF 8

- Maintenance cost is low
 - Working is simple
 - It is easy to install and replace
 - It occupies less space on the ground
- Disadvantages of simple vertical boiler
- The vertical design of this boiler limits its work in many places
 - Steam production is limited because of the limited area of the boiler shell.
 - The impurities settle at the bottom and thus prevent the water from heating up

The following are the application of a simple vertical boiler:

- Simple vertical boilers may have applications in railway locomotives, for example, a railway steam engine
- Simple vertical boilers are employed in road vehicles such as steam wagons or steam lorry
- The simple vertical boiler has a very well-known application which is a steam tractor
- The number of boats is particularly small which use simple vertical boilers to power the engine

2) Cochran Boiler:

Cochran boiler is a modified form of a simple vertical boiler where the heating surface has been extended through several methods. This is a fire tube boiler of a vertical type with multiple horizontal fire tubes. The efficiency of this boiler is much better than that of a simple vertical boiler. The Cochran boiler has an external cylindrical shell and a firebox. The shape of the shell and firebox is hemispherical and the hemispherical head of the boiler provides maximum space and strength for withstanding the pressure built up in the boiler. Also, the hemispherical crown of the firebox is helpful to resist intense heat.



PRACTICAL EXPERIMENT INSTRUCTION SHEET

EXPERIMENT TITLE: Study of Boilers

DEPARTMENT:MECHANICAL ENGINEERING

LABORATORY :CSMSS/ENGG/MECH/TD LAB

LABORATORY MANUAL
NO.:CSMSS/ENGG/MECH/TD

YEAR:2024-25

Class: Third Year

PART: II

SUBJECT: Applied Thermodynamics

PAGE: 6 OF 8

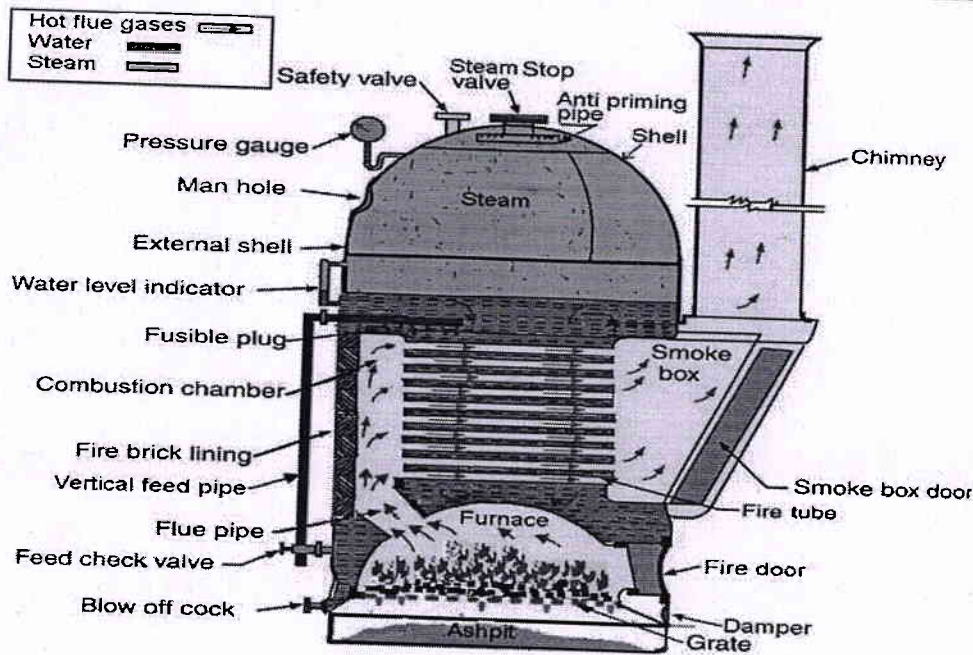

Cochran boiler

Construction and working: Cochran boiler consists of an external cylindrical shell. The construction of the Cochran boiler can be divided into three parts such as firebox, combustion chamber, and steam space. The shell and fire box are both hemispherical shapes. The hemispherical crown of the boiler shell gives maximum space and strength to withstand the pressure of steam inside the boiler. The firebox is also hemispherical in shape and has the advantage of resisting intense heat. Flue gases flow from the firebox to refractory material lined combustion chamber through a flue pipe. These flue gases flow through several smoke tubes. The gases from the smokebox pass to the atmosphere through a chimney. A manhole near the top of the crown on the shell is provided for cleaning. At the bottom of the firebox, there is a grate, and the coal is fed through the fire hole. If the boiler is used for oil firing, then no grate is provided, but the bottom of the firebox is lined with fire bricks. It also provided all required mountings as:



CHH. SHAHU COLLEGE OF ENGINEERING, AURANGABAD

LABORATORY
MANUAL

PRACTICAL EXPERIMENT INSTRUCTION SHEET

EXPERIMENT TITLE: Study of Boilers

DEPARTMENT:MECHANICAL ENGINEERING

LABORATORY :CSMSS/ENGG/MECH/TD LAB

LABORATORY MANUAL
NO.:CSMSS/ENGG/MECH/TD

YEAR:2024-25

Class: Third Year

PART: II

SUBJECT: Applied Thermodynamics

PAGE: 7 OF 8

- Pressure gauge
- Water level indicator
- Safety valve
- Fusible plug
- Blow off cock
- Steam stop valve
- Feed check valve

This boiler has the following important classification:

- It is a vertical boiler
- It is a multi-tube boiler
- It is a fire tube boiler
- It is an internally fired boiler
- It is a low-pressure boiler
- It is a stationary boiler
- It is a naturally circulated boiler
- It is a solid or liquid fuel-burning boiler
- **Uses of Cochran boiler:** The Cochran boiler was produced by Cochran & Co. of Annan, Scotland. It is widely used in marine practice, either fired directly by coal or oil fuels or else used for heat recovery from the exhaust of large diesel engines. The boiler is a cylindrical vertical water drum with a hemispherical domed top.

Babcock and Wilcox boiler

Babcock and Wilcox boiler is a water tube boiler with a large evaporation capacity or large-sized boiler. A model of the Babcock and Wilcox boiler.. This is a stationary type water tube boiler, which consists of the water drum at the top. A short tube is connected to the water drum with the help of the uptake header and

	CHH. SHAHU COLLEGE OF ENGINEERING, AURANGABAD		LABORATORY MANUAL
	PRACTICAL EXPERIMENT INSTRUCTION SHEET		
EXPERIMENT TITLE: Study of Boilers			
DEPARTMENT: MECHANICAL ENGINEERING		LABORATORY : CSMSS/ENGG/MECH/TD LAB	
LABORATORY MANUAL NO.: CSMSS/ENGG/MECH/TD		YEAR: 2024-25	
Class: Third Year	PART: II	SUBJECT: Applied Thermodynamics	PAGE: 8 OF 8

down header. A mud box is provided with each down space header in order to remove unwanted particles like the encrustation of salts, mud, etc.



Babcock and Wilcox Boiler

It has three main parts:

- Steam and water drum
- Water tubes
- Furnace

	CHH. SHAHU COLLEGE OF ENGINEERING, AURANGABAD		LABORATORY MANUAL
	PRACTICAL EXPERIMENT INSTRUCTION SHEET		
EXPERIMENT TITLE: Study of Boilers			
DEPARTMENT:MECHANICAL ENGINEERING		LABORATORY :CSMSS/ENGG/MECH/TD LAB	
LABORATORY MANUAL NO.:CSMSS/ENGG/MECH/TD		YEAR:2024-25	
Class: Third Year	PART: II	SUBJECT: Applied Thermodynamics	PAGE: 9 OF 8

Steam and water drum

A steam and water drum is a long drum fabricated using small shells riveted together. End cover plates can be opened as and when required. The drum is followed by water tubes which are arranged below the drum and connected to and drum through headers. Blow-off cock for blowing out the sediments settled in the mud box. Super heater tubes are also shown in arrangement, which is U – shaped tubes placed horizontally between drum and water tubes. Below the super heater and water tubes is the furnace, at the front of which the fuel feed hopper is attached. Bridge walls and baffles made of fire-resistant bricks are constructed to facilitate hot gases moving upwards from the grate area and then downwards. A smokebox is put at the back of the furnace through which smoke goes via a chimney. A damper is used for regulating pressure differences causing the expulsion of hot gases.

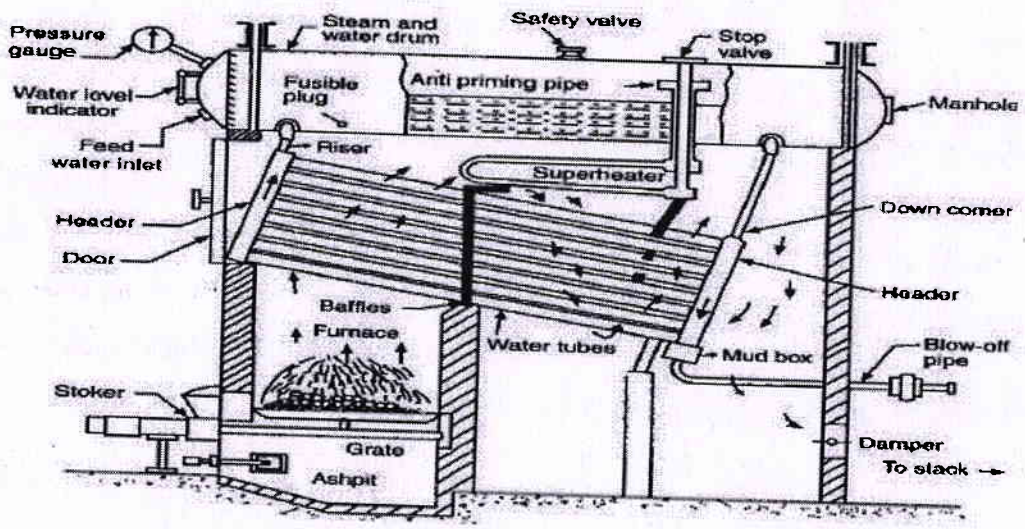

Line diagram of Babcock and Wilcox Boiler

	CHH. SHAHU COLLEGE OF ENGINEERING, AURANGABAD		LABORATORY MANUAL
	PRACTICAL EXPERIMENT INSTRUCTION SHEET		
EXPERIMENT TITLE: Study of Boilers			
DEPARTMENT: MECHANICAL ENGINEERING		LABORATORY : CSMSS/ENGG/MECH/TD LAB	
LABORATORY MANUAL NO.: CSMSS/ENGG/MECH/TD		YEAR: 2024-25	
Class: Third Year	PART: II	SUBJECT: Applied Thermodynamics	PAGE: 10 OF 8

A Babcock and Wilcox boiler fitted with the following mountings for safe working of the boiler:

- Pressure gauge
- Water level indicator
- Safety valve
- Fusible plug
- Blow off cock
- Steam stop valve

Feed check valve working: First, the water starts to come in the water tubes from the drum through the down-take header. The water present in the inclined water tubes gets heated up by the hot flue gases. The coal burning on the grate produces hot flue gases and it is forced to move in a zigzag way with the help of baffle plates.

As the hot flue gases come in contact with water tubes, it exchanges the heat with water and converts it into steam. The steam generated is moved upward and through the uptake header, it gets collected at the upper side of the boiler drum. An anti-priming pipe is provided in the drum. This anti-priming pipe filters the water content from the steam and allows only dry steam to enter the super heater. The super heater receives water-free steam from the anti-priming pipe. It increases the temperature of the steam to the desired level and transfers it to the steam stop valve. The superheated steam from the steam stop valve is either collected in a steam drum or made to strike on the steam turbine for electricity generation.



CHH. SHAHU COLLEGE OF ENGINEERING, AURANGABAD

LABORATORY
MANUAL

PRACTICAL EXPERIMENT INSTRUCTION SHEET

EXPERIMENT TITLE: Study of Boilers

DEPARTMENT: MECHANICAL ENGINEERING

LABORATORY : CSMSS/ENGG/MECH/TD LAB

LABORATORY MANUAL
NO.: CSMSS/ENGG/MECH/TD

YEAR: 2024-25

Class: Third Year

PART: II

SUBJECT: Applied Thermodynamics

PAGE: 11 OF 8

This boiler is large-sized and cannot be easily transported from one place to the other. It is a very popular boiler to be used in a power station.

This boiler has the following important classification:

- It is a horizontal boiler
- It is a multi-tube boiler
- It is a water tube boiler
- It is an externally fired boiler
- It is a stationary boiler
- It is a naturally circulated boiler
- It is a medium/high-pressure boiler

	CHH. SHAHU COLLEGE OF ENGINEERING, AURANGABAD		LABORATORY MANUAL
	PRACTICAL EXPERIMENT INSTRUCTION SHEET		
EXPERIMENT TITLE: Study of Boilers			
DEPARTMENT:MECHANICAL ENGINEERING		LABORATORY :CSMSS/ENGG/MECH/TD LAB	
LABORATORY MANUAL NO.:CSMSS/ENGG/MECH/TD		YEAR:2024-25	
Class: Third Year	PART: II	SUBJECT: Applied Thermodynamics	PAGE: 12 OF 8

Boiler Mountings:

Boiler mountings are a set of safety devices installed for the safe operation of a boiler. There are seven main mountings on a boiler shell; safety valve, steam stop valve, vent valve, pressure gauge, water level indicator, feed check valve, and fusible plug.

Boiler mountings are a set of safety devices fitted on a boiler for its protection and complete control of the steam generation cycle.

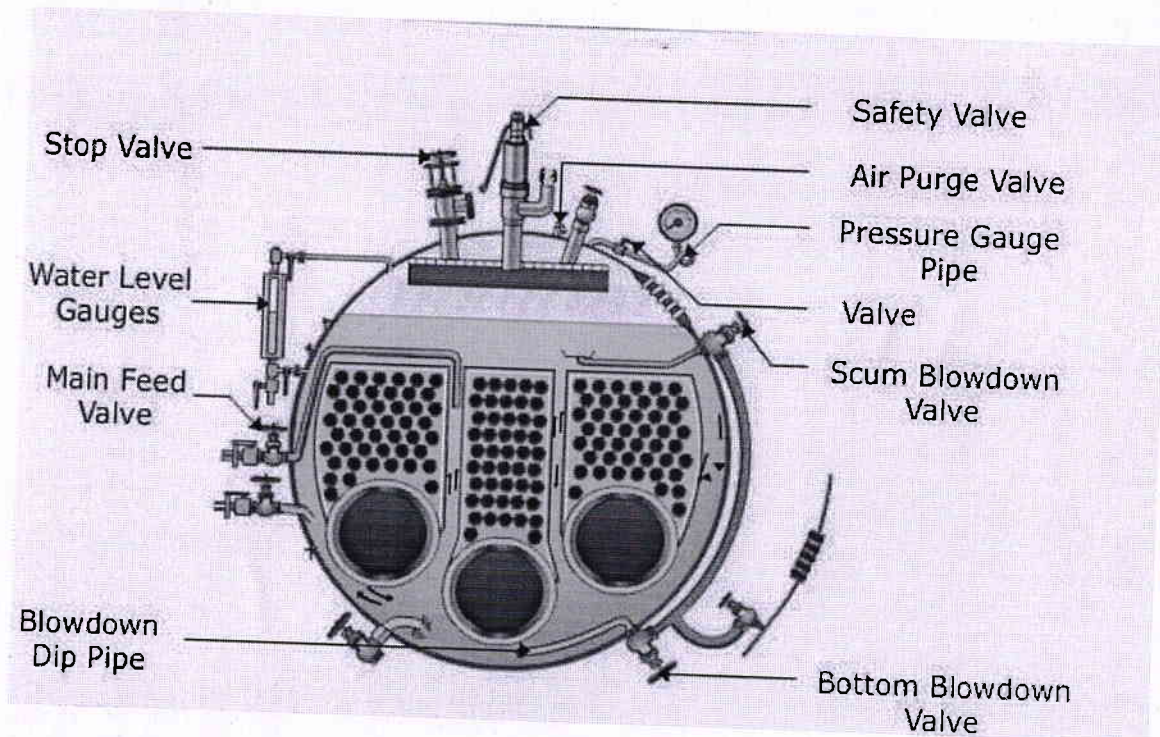

Mountings which are generally fitted on a boiler

Steam stop valve

It regulates the flow of steam from a boiler to a steam turbine through a pipe. This is generally mounted on the highest part of the boiler shell and performs the function of regulating the flow of steam from a boiler as shown in Fig. 10. Steam stop valve generally has the main body of cast iron,



CHH. SHAHU COLLEGE OF ENGINEERING, AURANGABAD

LABORATORY
MANUAL

PRACTICAL EXPERIMENT INSTRUCTION SHEET

EXPERIMENT TITLE: Study of Boilers

DEPARTMENT: MECHANICAL ENGINEERING

LABORATORY : CSMSS/ENGG/MECH/TD LAB

LABORATORY MANUAL
NO.: CSMSS/ENGG/MECH/TD

YEAR: 2024-25

Class: Third Year

PART: II

SUBJECT: Applied Thermodynamics

PAGE: 13 OF 8

valve, valve seat, nut, etc. are of brass. It can be easily operated by rotating the hand wheel which causes the lifting or lowering of a spindle, thus causing the opening or closing of a valve. This spindle passes out of glands and the stuffing box that is formed in the cover of the body.

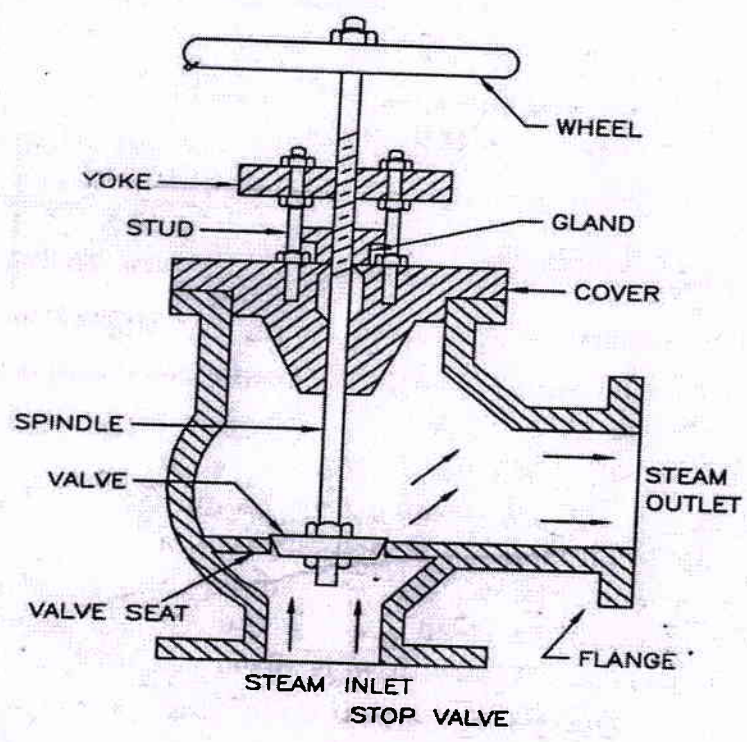

Steam stop valve

- 1) Lever safety valve
2. Deadweight safety valve
3. Spring-loaded safety valve
4. High steam and low water safety valve



CHH. SHAHU COLLEGE OF ENGINEERING, AURANGABAD

LABORATORY
MANUAL

PRACTICAL EXPERIMENT INSTRUCTION SHEET

EXPERIMENT TITLE: Study of Boilers

DEPARTMENT: MECHANICAL ENGINEERING

LABORATORY : CSMSS/ENGG/MECH/TD LAB

LABORATORY MANUAL
NO.: CSMSS/ENGG/MECH/TD

YEAR: 2024-25

Class: Third Year

PART: II

SUBJECT: Applied Thermodynamics

PAGE: 14 OF 8

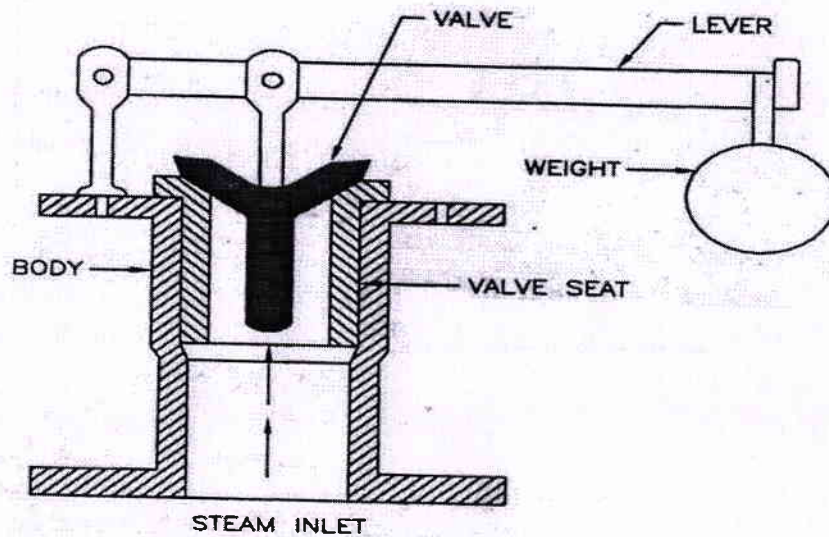

Lever Safety Valve

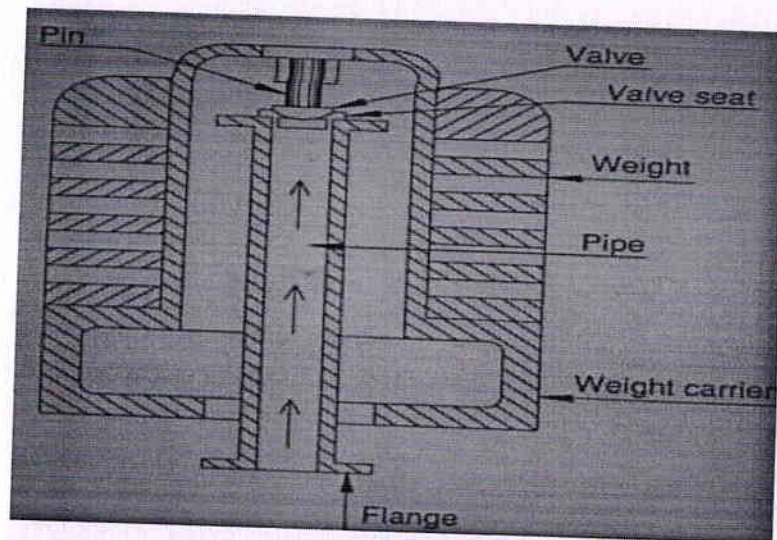

Dead weight safety valve



PRACTICAL EXPERIMENT INSTRUCTION SHEET

EXPERIMENT TITLE: Study of Boilers

DEPARTMENT: MECHANICAL ENGINEERING

LABORATORY : CSMSS/ENGG/MECH/TD LAB

LABORATORY MANUAL
NO.: CSMSS/ENGG/MECH/TD

YEAR: 2024-25

Class: Third Year

PART: II

SUBJECT: Applied Thermodynamics

PAGE: 15 OF 8

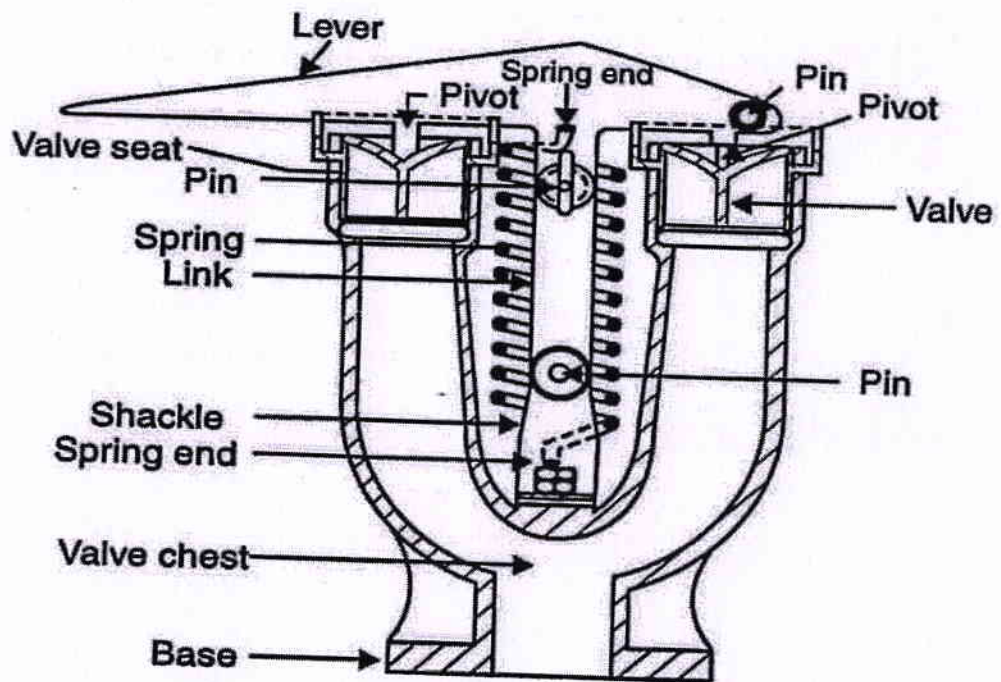

Spring-loaded safety valve

Blow off Cock:

The blow-off cock is fitted at the lowest part of a boiler shell. It is used to remove for periodical cleaning by discharging the water and sediments that are collected at the bottom of the boiler. It has a plug of the conical shape, put into the mating casing as shown in Fig. The plug position is altered for opening and closing the flow. It also helps in regulating the salt concentration as frequent draining helps in throwing out the salt deposited over a while. Further, it is used for emptying the boiler whenever it is to be cleaned. The casing has two flanges to which the blow-off cock is connected to the boiler by one flange and the other flange is connected to the pipe carrying the blow-off water out from the boiler.



CHH. SHAHU COLLEGE OF ENGINEERING, AURANGABAD

LABORATORY
MANUAL

PRACTICAL EXPERIMENT INSTRUCTION SHEET

EXPERIMENT TITLE: Study of Boilers

DEPARTMENT: MECHANICAL ENGINEERING

LABORATORY : CSMSS/ENGG/MECH/TD LAB

LABORATORY MANUAL
NO.: CSMSS/ENGG/MECH/TD

YEAR: 2024-25

Class: Third Year

PART: II

SUBJECT: Applied Thermodynamics

PAGE: 16 OF 8

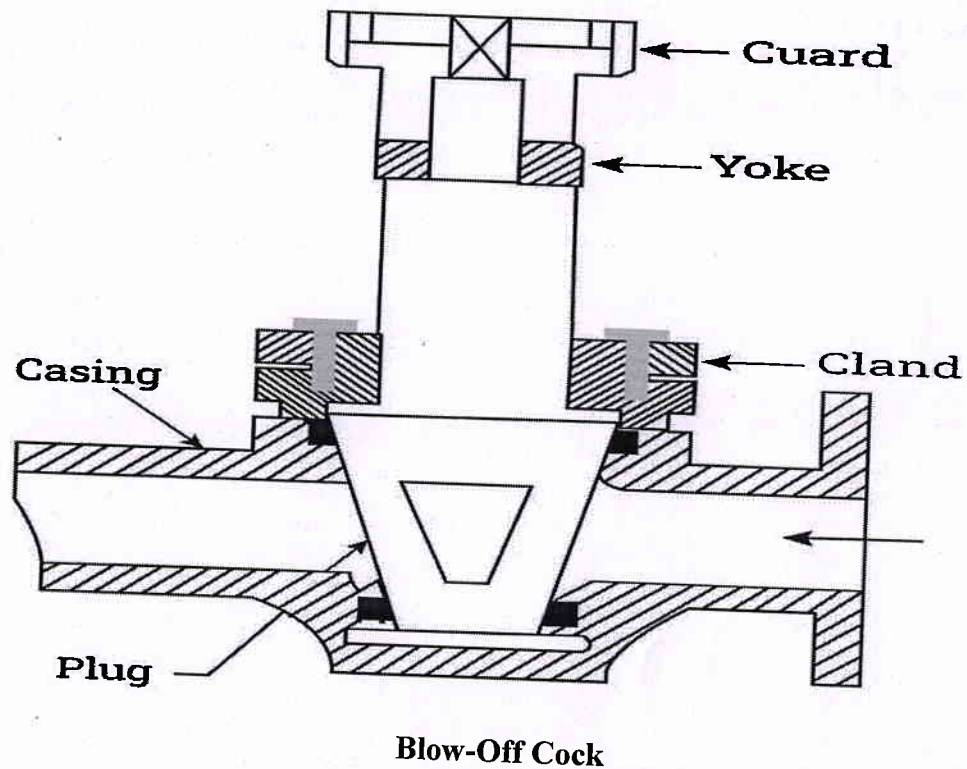

Feed Check Valve:

It is a non-return valve at the end of the delivery pipe from the feed water pump and is placed on the boiler shell slightly below the normal water level. It has a check valve whose opening and closing are regulated by the position of the spindle. The feed check valve permits a unidirectional flow of water from the feed pump to be boiler shell. It is used to feed and control the flow of water from the feed pump into the boiler. While during the non-working of a feed pump the pressure in the boiler shell is more and so the feed check valve gets closed.



CHH. SHAHU COLLEGE OF ENGINEERING, AURANGABAD

LABORATORY
MANUAL

PRACTICAL EXPERIMENT INSTRUCTION SHEET

EXPERIMENT TITLE: Study of Boilers

DEPARTMENT: MECHANICAL ENGINEERING

LABORATORY : CSMSS/ENGG/MECH/TD LAB

LABORATORY MANUAL
NO.: CSMSS/ENGG/MECH/TD

YEAR: 2024-25

Class: Third Year

PART: II

SUBJECT: Applied Thermodynamics

PAGE: 17 OF 8

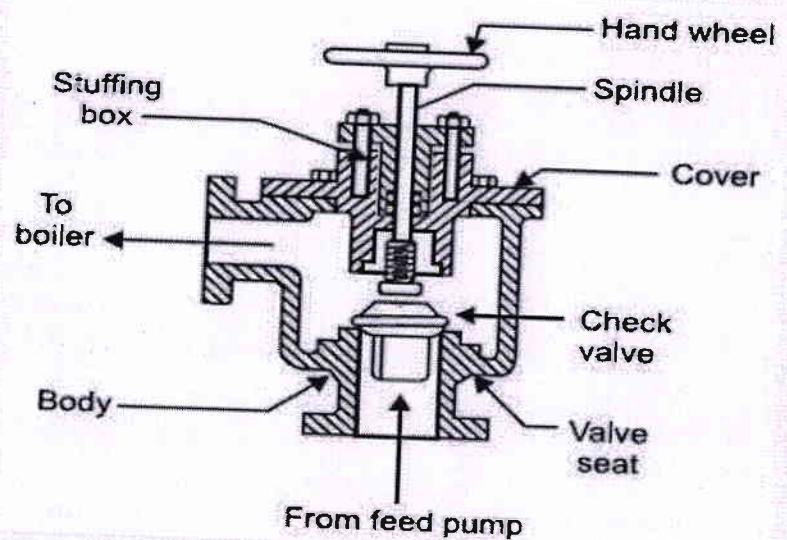

Feed Check Valve